

User Manual



SPG 422
Component Digital Sync Generator
S/N B020000 and above

071-0034-00

This document supports firmware version 1.3.0
and above.



Copyright © Tektronix, Inc. All rights reserved.

Tektronix products are covered by U.S. and foreign patents, issued and pending. Information in this publication supercedes that in all previously published material. Specifications and price change privileges reserved.

Printed in the U.S.A.

Tektronix, Inc., P.O. Box 1000, Wilsonville, OR 97070-1000

TEKTRONIX and TEK are registered trademarks of Tektronix, Inc.

WARRANTY

Tektronix warrants that the products that it manufactures and sells will be free from defects in materials and workmanship for a period of one (1) year from the date of shipment. If a product proves defective during this warranty period, Tektronix, at its option, either will repair the defective product without charge for parts and labor, or will provide a replacement in exchange for the defective product.

In order to obtain service under this warranty, Customer must notify Tektronix of the defect before the expiration of the warranty period and make suitable arrangements for the performance of service. Customer shall be responsible for packaging and shipping the defective product to the service center designated by Tektronix, with shipping charges prepaid. Tektronix shall pay for the return of the product to Customer if the shipment is to a location within the country in which the Tektronix service center is located. Customer shall be responsible for paying all shipping charges, duties, taxes, and any other charges for products returned to any other locations.

This warranty shall not apply to any defect, failure or damage caused by improper use or improper or inadequate maintenance and care. Tektronix shall not be obligated to furnish service under this warranty a) to repair damage resulting from attempts by personnel other than Tektronix representatives to install, repair or service the product; b) to repair damage resulting from improper use or connection to incompatible equipment; c) to repair any damage or malfunction caused by the use of non-Tektronix supplies; or d) to service a product that has been modified or integrated with other products when the effect of such modification or integration increases the time or difficulty of servicing the product.

THIS WARRANTY IS GIVEN BY TEKTRONIX IN LIEU OF ANY OTHER WARRANTIES, EXPRESS OR IMPLIED. TEKTRONIX AND ITS VENDORS DISCLAIM ANY IMPLIED WARRANTIES OF MERCHANTABILITY OR FITNESS FOR A PARTICULAR PURPOSE. TEKTRONIX' RESPONSIBILITY TO REPAIR OR REPLACE DEFECTIVE PRODUCTS IS THE SOLE AND EXCLUSIVE REMEDY PROVIDED TO THE CUSTOMER FOR BREACH OF THIS WARRANTY. TEKTRONIX AND ITS VENDORS WILL NOT BE LIABLE FOR ANY INDIRECT, SPECIAL, INCIDENTAL, OR CONSEQUENTIAL DAMAGES IRRESPECTIVE OF WHETHER TEKTRONIX OR THE VENDOR HAS ADVANCE NOTICE OF THE POSSIBILITY OF SUCH DAMAGES.

Service Assurance

If you have not already purchased Service Assurance for this product, you may do so at any time during the product's warranty period. Service Assurance provides Repair Protection and Calibration Services to meet your needs.

Repair Protection extends priority repair services beyond the product's warranty period; you may purchase up to three years of Repair Protection.

Calibration Services provide annual calibration of your product, standards compliance and required audit documentation, recall assurance, and reminder notification of scheduled calibration. Coverage begins upon registration; you may purchase up to five years of Calibration Services.

Service Assurance Advantages

- Priced well below the cost of a single repair or calibration
- Avoid delays for service by eliminating the need for separate purchase authorizations from your company
- Eliminates unexpected service expenses

For Information and Ordering

For more information or to order Service Assurance, contact your Tektronix representative and provide the information below. Service Assurance may not be available in locations outside the United States of America.

Name	VISA or Master Card number and expiration
Company	date or purchase order number
Address	Repair Protection (1,2, or 3 years)
City, State, Postal code	Calibration Services (1,2,3,4, or 5 years)
Country	Instrument model and serial number
Phone	Instrument purchase date

Table of Contents

List of Figures	iii
List of Tables	vi
General Safety Summary	vii
Preface	ix
About This Manual	ix
Related Manuals	ix
Contacting Tektronix	x
Getting Started	
Getting Started	1-1
Packaging	1-1
Product Description	1-2
Front-Panel Controls	1-2
Rear Panel Connectors	1-3
Installation	1-4
Operating Basics	
Operating Basics	2-1
Genlock	2-1
Genlock Video Standard	2-1
Genlock Input Configuration	2-2
Genlock Timing	2-2
Black Signals	2-3
Bars Signals	2-3
Serial Black	2-3
Audio Signals	2-4
Serial Signals (Option 2 only)	2-4
Reference	
Reference	3-1
Using the Front Panel and Menu	3-1
Menus Available from the Main Menu	3-3
Main Menu	3-3
Presets Submenu	3-5
Utility Submenu	3-7
Diagnostic Submenu	3-9
Menus Available from the Select Buttons	3-13
Genlock Menu	3-14
Serial Bars Menu	3-16
Serial Audio Menu	3-18
Black Menus	3-24
Serial Signals Menu	3-26
Timing Submenu	3-28
Using the RS-232 Remote	3-31
RS-232 Command Summary	3-33

General Command Information	3-38
Explanation of the Parser Commands	3-39
DIAGNOSTIC Commands	3-40
DISPLAY Commands	3-42
INPUT Commands	3-42
OUTPUT Commands	3-44
STATUS Commands	3-51
SYSTEM Commands	3-53
Using the Ground-Closure Remote	3-56

Appendix

Appendix A: Specifications	A-1
Performance Conditions	A-1
Characteristics Tables	A-2
Signal Illustrations	A-27

List of Figures

Figure 1–1: Illustration of the SPG 422 Front Panel	1–2
Figure 1–2: Illustration of the SPG 422 Rear Panel	1–3
Figure 1–3: Front Rail Mount	1–6
Figure 1–4: Deep Rackmount and Shallow Rackmount	1–7
Figure 1–5: Assembly of Rackmounting Hardware	1–7
Figure 1–6: Installing the Instrument in the Rack Slides	1–8
Figure 2–1: Front Panel of the SPG 422	2–1
Figure 2–2: Various Ways the Genlock Input can be Configured ...	2–2
Figure 2–3: Illustration of the SPG 422 Timing	2–5
Figure 3–1: Illustration of the SPG422 Main Menu (V1.3.0)	3–2
Figure 3–2: How the Menus are accessed using the select Buttons and their relationship to the Main Menu	3–14
Figure 3–3: The Genlock Menu Structure	3–15
Figure 3–4: The Serial Bars Menu Structure	3–17
Figure 3–5: The Serial Audio Menu	3–19
Figure 3–6: Black 1 and 2 Menu Structure	3–25
Figure 3–7: Black 3 through 6 Menu Structure	3–25
Figure 3–8: The Serial Signals Menu Structure	3–26
Figure 3–9: How to Connect the Terminal	3–31
Figure A–1: Timing Relationship between the Digital Video Data and the Analog line Synchronization (Reference for Line Scanning) in the 525/60 system	A–4
Figure A–2: Timing Relationship between the Digital Video Data and the Analog Line Synchronization (Reference for Line Scanning) in the 625/50 System	A–5
Figure A–3: Relationship between the Digital and Analog Fields, and the Position of the Digital Field-Blanking Interval in the 625 System	A–6
Figure A–4: Relationship of Video Data/Vertical Sync in the 525 System	A–7
Figure A–5: 60 Hz Black Burst with 7.5 IRE Setup	A–12
Figure A–6: 60 Hz Black Burst with No Setup	A–13
Figure A–7: 50 Hz Black Burst	A–13
Figure A–8: 75% Color Bars — Y Channel	A–27
Figure A–9: 75% Color Bars — CB Channel	A–27

Figure A-10: 75% Color Bars — CR Channel	A-28
Figure A-11: 100% Color Bars — Y Channel	A-28
Figure A-12: 100% Color Bars — CB Channel	A-29
Figure A-13: 100% Color Bars — CR Channel	A-29
Figure A-14: 75% Red — Y Channel	A-30
Figure A-15: 75% Red — CB Channel	A-30
Figure A-16: 75% Red — CR Channel	A-31
Figure A-17: 100% Red — Y Channel	A-31
Figure A-18: 100% Red — CB Channel	A-32
Figure A-19: 100% Red — CR Channel	A-32
Figure A-20: EIA Bars (Part of SMPTE Bars) — Y Channel	A-33
Figure A-21: EIA Bars (Part of SMPTE Bars) — CB Channel	A-33
Figure A-22: EIA Bars (Part of SMPTE Bars) — CR Channel	A-34
Figure A-23: IWQ Bars (Part of SMPTE Bars) — Y Channel	A-34
Figure A-24: IWQ Bars (Part of SMPTE Bars) — CB Channel	A-35
Figure A-25: IWQ Bars (Part of SMPTE Bars) — CR Channel	A-35
Figure A-26: Reverse Bars (Part of SMPTE Bars) — Y Channel ...	A-36
Figure A-27: Reverse Bars (Part of SMPTE Bars) — CB Channel ..	A-36
Figure A-28: Reverse Bars (Part of SMPTE Bars) — CR Channel .	A-37
Figure A-29: Multiburst — Y Channel	A-37
Figure A-30: Multiburst — CB and CR Channels	A-38
Figure A-31: Modulated Pulse and Bar — Y Channel	A-38
Figure A-32: Modulated Pulse and Bar — CB Channel	A-39
Figure A-33: Modulated Pulse and Bar — CR Channel	A-39
Figure A-34: Convergence (Horizontal) — Y Channel	A-40
Figure A-35: Convergence (Horizontal) — CB and CR Channels ..	A-40
Figure A-36: Convergence (Vertical) — Y Channel	A-41
Figure A-37: Convergence (Vertical) — CB and CR Channels	A-41
Figure A-38: Active Picture Markers (Part of Active Picture Timing Test Signal) — Y Channel	A-42
Figure A-39: Active Picture Markers (Part of Active Picture Timing Test Signal) — CB	A-42
Figure A-40: Active Picture Markers (Part of Active Picture Timing Test Signal) — CR	A-43
Figure A-41: White Bar (Also Part of Active Picture Timing Test Signal) — Y Channel	A-43
Figure A-42: White Bar (Also Part of Active Picture Timing Test Signal) — CB and CR Channels	A-44
Figure A-43: Bowtie Sweep — Y Channel	A-44

Figure A-44: Bowtie — CB and CR Channels	A-45
Figure A-45: Bowtie Markers — Y Channel	A-45
Figure A-46: Ramp — Y Channel	A-46
Figure A-47: Ramp — CB Channel	A-46
Figure A-48: Ramp — CR Channel	A-47
Figure A-49: Pluge — Y Channel	A-47
Figure A-50: Pluge — CB and CR Channels	A-48

List of Tables

Table 1–1: Front Panel Control, J13	1–5
Table 1–2: Front Panel Timeout, S1–2	1–5
Table A–1: Encoding Parameters for Serial Digital Video Outputs .	A–2
Table A–2: Timing Relationships for Serial Digital Video Outputs .	A–3
Table A–3: Output Characteristics for Serial Digital Video Signals .	A–8
Table A–4: Signal Characteristics for Analog Black Outputs (in base instrument only)	A–9
Table A–5: Signal Characteristics for Analog Black Outputs (in Option 1 only)	A–11
Table A–6: Signal Characteristics for Serial Bars Output	A–14
Table A–7: Signal Characteristics for Serial Test Signal (Option 2 only)	A–15
Table A–8: Signal Characteristics for AES/EBU Serial Digital Audio Outputs (XLR connectors)	A–16
Table A–9: Signal Characteristics for AES/EBU Serial Digital Audio Outputs (BNC outputs)	A–17
Table A–10: Signal Characteristics for Embedded Serial Audio	A–18
Table A–11: 20-bit Audio Signal Sample Distribution for Embedded Serial Audio on 525/59.94 Signals	A–19
Table A–12: 20-bit Audio Signal Sample Distribution for Embedded Serial Audio on 625/50 Signals	A–20
Table A–13: Audio Channel Status Bits (Serial and Embedded Audio Data Streams)	A–21
Table A–14: Genlock Function	A–22
Table A–15: Power Supply	A–23
Table A–16: Mechanical (Physical) Characteristics	A–24
Table A–17: Environmental Characteristics	A–24
Table A–18: Certifications and Compliances	A–25

General Safety Summary

Review the following safety precautions to avoid injury and prevent damage to this product or any products connected to it. To avoid potential hazards, use this product only as specified.

Only qualified personnel should perform service procedures.

To Avoid Fire or Personal Injury

Use Proper Power Cord. Use only the power cord specified for this product and certified for the country of use.

Connect and Disconnect Properly. Do not connect or disconnect probes or test leads while they are connected to a voltage source.

Ground the Product. This product is grounded through the grounding conductor of the power cord. To avoid electric shock, the grounding conductor must be connected to earth ground. Before making connections to the input or output terminals of the product, ensure that the product is properly grounded.

Observe All Terminal Ratings. To avoid fire or shock hazard, observe all ratings and markings on the product. Consult the product manual for further ratings information before making connections to the product.

Do not apply a potential to any terminal, including the common terminal, that exceeds the maximum rating of that terminal.

Do Not Operate Without Covers. Do not operate this product with covers or panels removed.

Use Proper Fuse. Use only the fuse type and rating specified for this product.

Avoid Exposed Circuitry. Do not touch exposed connections and components when power is present.

Wear Eye Protection. Wear eye protection if exposure to high-intensity rays or laser radiation exists.

Do Not Operate With Suspected Failures. If you suspect there is damage to this product, have it inspected by qualified service personnel.

Do Not Operate in Wet/Damp Conditions.

Do Not Operate in an Explosive Atmosphere.

Keep Product Surfaces Clean and Dry.

Provide Proper Ventilation. Refer to the manual's installation instructions for details on installing the product so it has proper ventilation.

Symbols and Terms

Terms in this Manual. These terms may appear in this manual:



WARNING. *Warning statements identify conditions or practices that could result in injury or loss of life.*



CAUTION. *Caution statements identify conditions or practices that could result in damage to this product or other property.*

Terms on the Product. These terms may appear on the product:

DANGER indicates an injury hazard immediately accessible as you read the marking.

WARNING indicates an injury hazard not immediately accessible as you read the marking.

CAUTION indicates a hazard to property including the product.

Symbols on the Product. The following symbols may appear on the product:



WARNING
High Voltage



Protective Ground
(Earth) Terminal



CAUTION
Refer to Manual



Double
Insulated

Preface

This manual describes the capabilities of the SPG 422 Component Sync Pulse Generator, and its features and specifications.

To begin, refer to the first section, *Getting Started*. This section shows you how to install and configure the SPG 422 for use in your operating system. For detailed information about a feature or menu, refer to the third section, *Reference*.

About This Manual

This manual is composed of the following sections:

- *Getting Started* provides a product description, installation instructions, and a functional check procedure. Standard and optional accessories are also listed.
- *Operating Basics* briefly describes the front panel controls and rear panel connections.
- *Reference* provides a detailed reference for all front panel menus and remote control interfaces of the SPG 422.
- *Appendices* provide additional information, such as specifications.

Related Manuals

The following related document is also available.

- The *SPG 422 Service Manual* (071-0035-XX) describes how to service the SPG 422. This optional manual must be ordered separately.

Contacting Tektronix

Product Support	<p>For application-oriented questions about a Tektronix measurement product, call toll free in North America: 1-800-TEK-WIDE (1-800-835-9433 ext. 2440) 6:00 a.m. – 5:00 p.m. Pacific time</p> <p>Or, contact us by e-mail: tm_app_supp@tek.com</p> <p>For product support outside of North America, contact your local Tektronix distributor or sales office.</p>
Service Support	<p>Contact your local Tektronix distributor or sales office. Or, visit our web site for a listing of worldwide service locations.</p> <p>http://www.tek.com</p>
For other information	<p>In North America: 1-800-TEK-WIDE (1-800-835-9433) An operator will direct your call.</p>
To write us	<p>Tektronix, Inc. P.O. Box 1000 Wilsonville, OR 97070-1000</p>



Getting Started

Getting Started

NOTE. The following features are not fully implemented in the current version of the SPG 422:

- The RS-232 Remote SCPI commands.
- The NTSC Audio Timing Reference. (PAL Audio Timing Reference is operational.)

This section provides the information necessary to install and become familiar with the SPG 422 Component Digital Sync Generator in its operating environment. It includes a discussion of the rear-panel connectors, electrical and mechanical installation, setting for the internal jumpers, and a tutorial to become familiar with the menu and front panel operation.

Packaging

The shipping carton and pads provide protection for the instrument during transit. Retain the shipping cartons in case subsequent shipment becomes necessary. The *Service* section of this manual contains the repackaging instructions.

Front

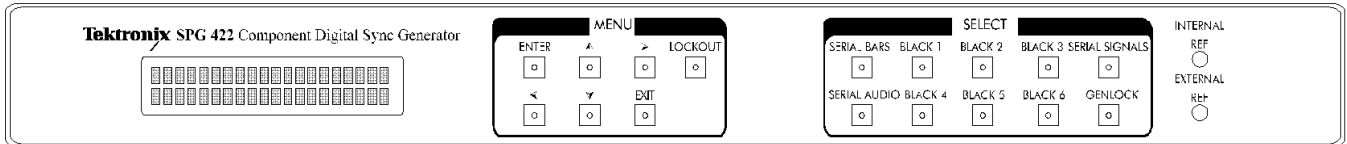

Rear

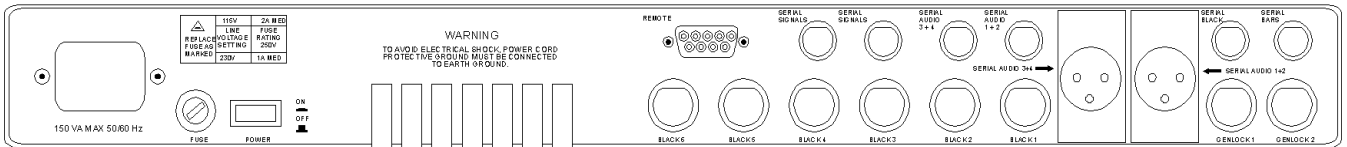

Product Description

The SPG 422 is a component digital sync pulse generator (SPG). The SPG 422 provides basic setup and timing signals for component digital tape recorders and processing equipment systems. It provides audio tones and a few simple Video Test signals needed to adjust equipment and stripe video tapes. Analog black signals are the timing reference signals of choice and the SPG 422 provides up to six analog black signals, each with separate timing controls. Because the SPG 422 has good frequency stability, it can perform as a stand-alone generator or genlock to an external PAL or NTSC signal.

Some installations use 525/59.94 and 625/50 Component signals simultaneously or switch between standards regularly. Dual-standard operation is possible with the SPG 422 architecture. Also important for dual-standard operation, is the ability of the SPG 422 to output audio tones locked to the video standard(s) in use.

The SPG 422 has a front-panel interface that controls all instrument functions. Also, the user can control the SPG 422 via either a parallel ground-closure remote or RS-232. The ground-closure remote provides simple control of a few major instrument functions, while the RS-232 implementation is a SCPI (Standard Commands for Programmable Instruments) command language interface, with most of the front-panel interface capabilities. (Not all commands are implemented at this time.)

Front-Panel Controls

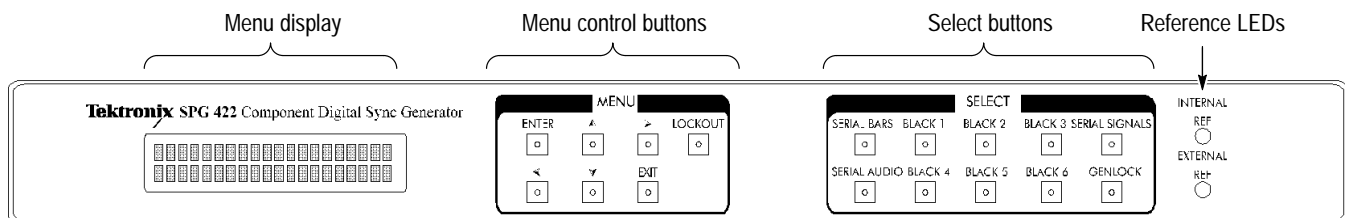

Figure 1-1: Illustration of the SPG 422 Front Panel

The front panel has four sections: the Menu Display, the Menu Control buttons, the Select buttons, and the Reference LEDs. (See Figure 1-1.)

Menu Display

This section of the front panel displays the current state of the SPG 422. Also used in conjunction with the Select and Menu Control buttons to change the configuration of the outputs.

Menu Control Buttons

This section of the front panel controls the Menu Display. The direction arrows control scrolling through the menu, while the Enter and Exit buttons accept changes or allow you to return to your original starting point. The LOCKOUT button is included in this group. See *Installation* in this section of the manual for details on the LOCKOUT button.

Select Buttons

Use the select button to select a specific menu.

Reference LEDs

The reference LEDs indicate whether the SPG 422 is externally genlocked or is using its internal oscillator.

More information on these controls is available in the *Operating Basics* and *Reference* sections of this manual.

Rear-Panel Connectors

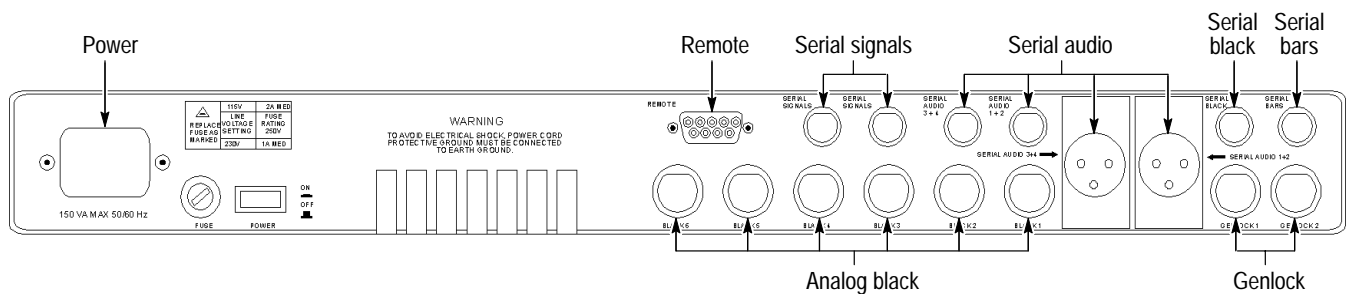

Figure 1-2: Illustration of the SPG 422 Rear Panel

The SPG 422 rear panel contains all of the connectors for the instrument. (See Figure 1-2.)

Power Connector. This instrument operates from a single-phase power source with one current-carrying conductor at or near earth-ground (the neutral conductor). Only the line conductor is fused for over current protection. Mains frequency is 50 or 60 Hz. The operating voltage range is continuous from 90 to 250 VAC.



WARNING. If the top cover is not in place, do not connect power to the SPG 422. Dangerous potentials are present on the Power Supply board.

Serial Bars. Serial digital color bars output. Set from the Serial Bars menu.

Serial Black. Serial Digital Black signal output. All its parameters are set by the Serial Bars menu.

Genlock 1 and 2. Accepts analog black burst or CW as the genlock input. Burst locks to NTSC and PAL Composite signals, sync locks to monochrome 525 and 626 signals, and CW lock to 1, 5, 10, 4.43, and 3.58 MHz. There are two termination options: loopthrough or single-ended. The loopthrough option requires external termination. When using the single-ended option, both inputs are internally terminated and either may be selected as the genlock source.

Black 1. Analog black output 1. Set from the Black 1 menu.

Black 2. Analog black output 2. Set from the Black 2 menu.

Black 3. Analog black output 3 (option 1 only). Set from the Black 3 menu. (This connector is plugged in the standard instrument.)

Black 4. Analog black output 4 (option 1 only). Set from the Black 4 menu. (This connector is plugged in the standard instrument.)

Black 5. Analog black output 5 (option 1 only). Set from the Black 5 menu. (This connector is plugged in the standard instrument.)

Black 6. Analog black output 6 (option 1 only). Set from the Black 6 menu. (This connector is plugged in the standard instrument.)

Serial Signals (2). Serial Digital Test signal outputs (option 2 only). (These connectors are plugged in the standard instrument.) Select the outputs from the Serial signals menu.

Remote. A 9-pin D-connector. Configure it as either a 9-pin ground-closure or a 9-pin RS-232 serial remote control. (Select the configuration by moving the cable connector within the instrument.)

Serial Audio 1+2 and Serial Audio 3+4 (BNC connector). AES/EBU serial digital audio output for channels 1 & 2 and 3 & 4 respectively. Set from the Serial Audio menu.

Serial Audio 1+2 and Serial Audio 3+4 (XLR connector). AES/EBU serial digital audio output for channels 1 & 2 and 3 & 4 respectively. Set from the Serial Audio menu.

Installation

Electrical Installation

As shipped from the factory, the front-panel lockout function is enabled. After power-up all of the front panel buttons are disabled. To make the front panel buttons operational, hold down the LOCKOUT button until its LED goes out.

The front panel is now active. If no button is pushed, the front panel times out after five minutes and the front-panel buttons are again disabled.

Disable Front Panel. The front panel may be disabled. This locks even the LOCKOUT button. None of the front-panel buttons have any effect. Jumper J13, located on the A2 Digital board between U12 and U21, is used to select this mode.

Table 1-1: Front Panel Control, J13

Position	Front Panel
1 – 2	Enabled
2 – 3	Disabled

Disable Lockout Timeout. You can disable the Front Panel Lockout Timeout. In this mode, the front-panel buttons are disabled after power up. Once the LOCKOUT button is pressed, the front panel will remain active until the LOCKOUT button is pressed again. Segment two of S1, located on the A2 Digital board, is used to select this mode. See Table 1-2.

NOTE. Do not change the position of any S1 segments except segment 2. All other switch segments are used for instrument diagnostics. Refer to the service manual for information on the other segments of S1.

Table 1-2: Front Panel Timeout, S1-2

S1 Segment 2	Timeout	
Open	Enabled	Lockout timing disables the keyboard after 5 minutes with no keypress. This prevents inadvertent keyboard selections from being made.
Closed	Disabled	Lockout timing is disabled (infinite delay). The Lockout button may still be used to disable the keyboard, and power-up will initially enable the lockout.

Rackmounting

The SPG 422 comes with the hardware for rackmounting. The instrument fits in a standard 19-inch rack. Spacing between the front rails of the rack must be at least 17-3/4 inches to allow clearance for the slide-out tracks. Rack slides conveniently mount in any rack that has a front-to-rear rail spacing between

15-1/2 and 28 inches. Six inches of clearance between the instrument rear panel and any rear cabinet panel is required for connector space and to provide adequate air circulation.

Mounting the Slide Tracks

Locate the proper rack holes.

Mount the rails using the enclosed hardware as shown. Figures 1-3 and 1-4 show the rail mounting details for both deep and shallow racks. Make sure that the stationary sections align horizontally, are level, and are parallel.

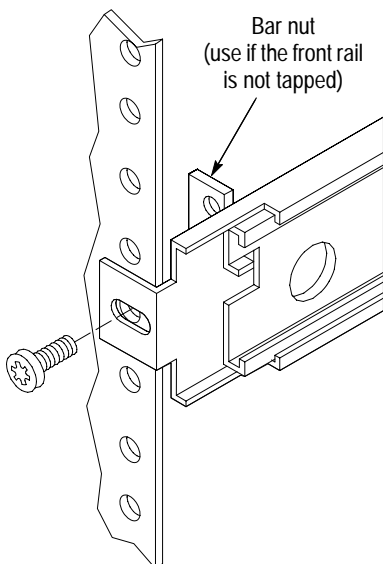

Figure 1-3: Front Rail Mount

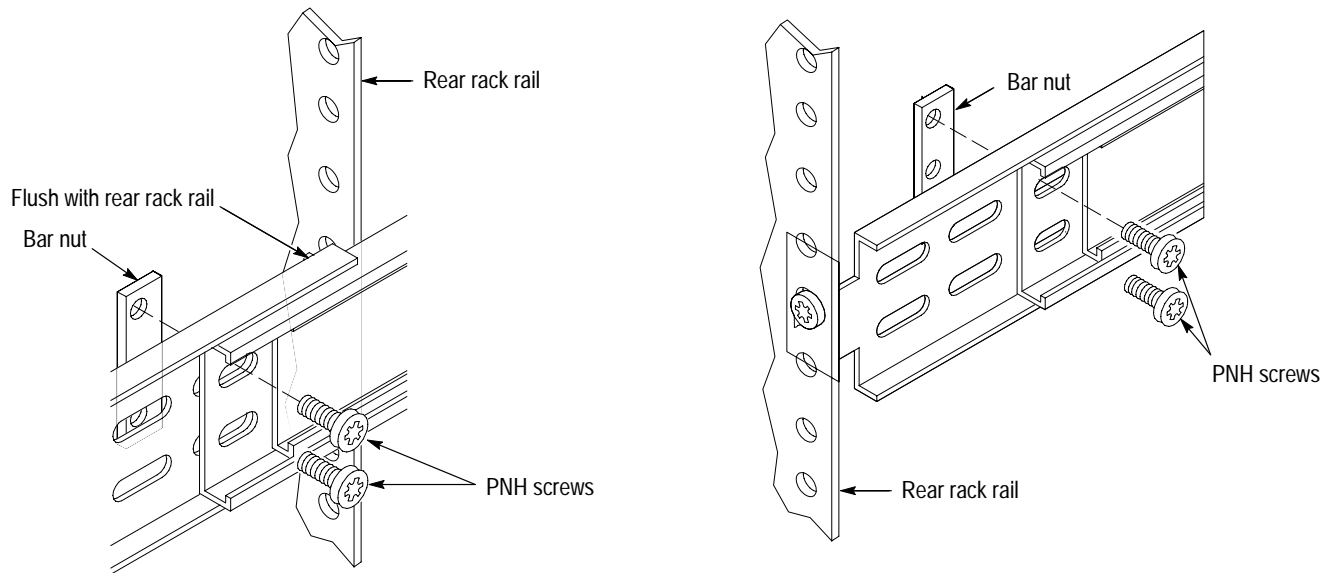

Figure 1-4: Deep Rackmount and Shallow Rackmount

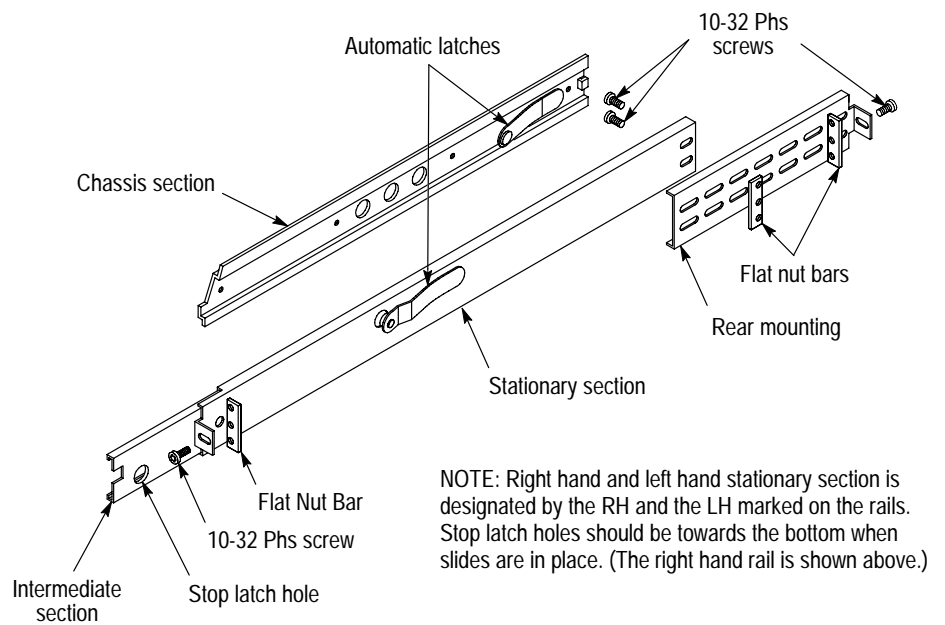
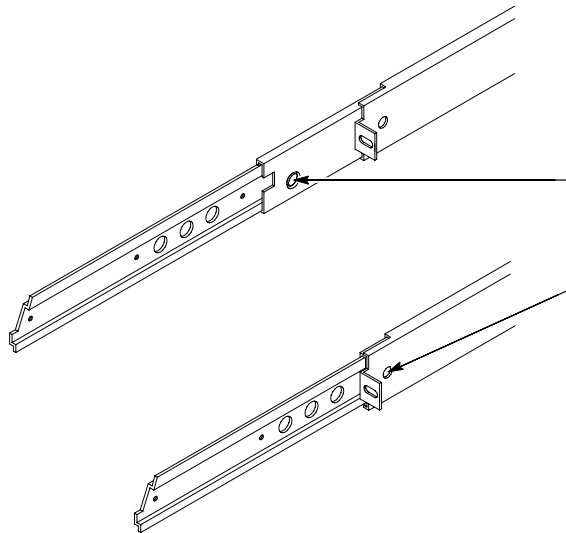

Figure 1-5: Assembly of Rackmounting Hardware

Installing the Instrument Install the instrument in the rack, as shown in Figure 1–6.



TO INSTALL:

1. Pull the slide-out track section to the fully extended position.
2. Insert the instrument chassis sections into the slide-out sections.
3. Press the stop latches and push the instrument toward the rack until the latches snap into their holes.
4. Again press the stop latches and push the instrument fully into the rack.
5. Tighten the front-panel retaining screw.

TO REMOVE:

1. Loosen retaining screw and pull instrument outward until the stop latches snap into the holes.
2. Press stop latches and remove instrument.

Figure 1–6: Installing the Instrument in the Rack Slides

Rack Adjustments

After installation, the slide tracks may bind if improperly adjusted. To adjust the tracks, slide the instrument out about 10 inches, slightly loosen the screws holding the tracks to the front rails, and allow the tracks to seek an unbound position. Re-tighten the screws and check the tracks for smooth operation by sliding the instrument in and out of the rack several times.

Once the instrument is in place within the rack, tighten the knurled retaining screw to fasten it securely into the rack.

Rack Slide Maintenance

The slide-out tracks do not require lubrication. The dark gray finish on the tracks is a permanent, lubricated coating.

Removing the Instrument

First, loosen the front-panel knurled retaining screw. Grasp the front handles and pull the instrument out until all three slide sections latch. This holds the instrument firmly in position.

To completely remove the instrument, first, be sure to disconnect all cabling. Then, press both release-latch buttons (visible in the stop-latch holes) and carefully slide the instrument free from the tracks.



Operating Basics

Operating Basics

There is one input and several different kinds of outputs available from the SPG 422. This section explains what these signals are and how to use them.

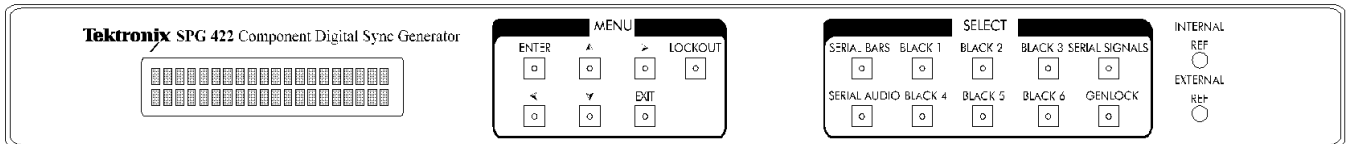

Figure 2-1: Front Panel of the SPG 422

Genlock

The genlock input accepts either NTSC, PAL, or CW inputs. The SPG 422 expects the input to be an Analog Black reference signal either with or without burst. If burst is not present, then the SPG 422 can lock to the sync (instead of burst lock). Configure the genlock as either a loophrough or two terminated inputs.

You can change the timing to compensate for any delays inherent in your system.

Please note that the SPG 422 cannot auto-detect the genlock input standard. Configure the genlock through the front panel or the RS-232 remote control. Setting up the Genlock Input signal has three parts: selecting video standard, selecting input configuration, and setting timing offset.

Genlock Video Standard

There are two different video standards to choose from (NTSC or PAL). Also you can choose between burst lock and sync lock.

You can also select from a list of Continuous Wave frequencies: 3.58, 4.43, 1.0, 5.0, or 10.0 MHz.

If the genlock is set to burst lock but the Input signal has no burst or it suddenly loses burst, the menu display of the SPG 422 will say: "Reference Unknown". All output signals will remain locked to the internal oscillator.

Genlock Input Configuration

You can connect the Genlock signal in three different ways. Figure 2–2 illustrates the various options.

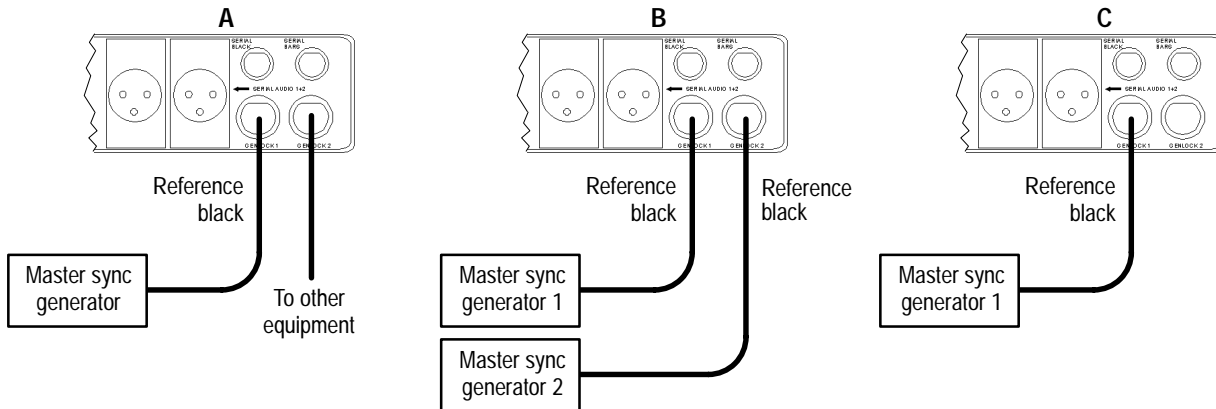

Figure 2–2: Various Ways the Genlock Input can be Configured

Loophrough

Figure 2–2A shows the genlock as a loopthrough signal from Genlock A to Genlock B. This application is common when the SPG 422 is close to the master sync generator and the master sync still has other equipment to feed.

Two References

Figure 2–2B shows two possible genlock inputs: Genlock 1 and Genlock 2. These are two different references. You can select which one you want from the front panel. (Remember that the unselected genlock input is still terminated.) An application for this setup is a dual standard suite. One genlock input would be the 525/59.94 standard and the other 625/50 standard. Set some blacks for each standard, and the user can quickly shift between the standards with a menu change.

Single Reference

Figure 2–2C shows a single genlock input. This is appropriate for the last signal in a reference chain.

Genlock Timing

The commands under this menu set the amount of advance or delay for all the output signals relative to the genlock input. The individual signals can then have their timing adjusted in their own menus.

You do not need to press ENTER for these commands. All changes will occur as you make them.

The submenus for genlock timing are: field timing, vertical offset, horizontal offset, and fine horizontal offset.

Genlock Field Timing

Sets the amount of field offset using the left or right arrows. The maximum amount of offset is two fields of advance or delay.

Genlock Vertical Offset

The Genlock Vertical Offset sets the amount of vertical offset using the left and right arrows. The amount of offset can range from eight lines advance to eight lines delay.

Genlock Horizontal Offset

Genlock Horizontal Offset sets the amount of horizontal offset using the right or left arrow keys. It will move in units of clock cycles so the exact amount will vary depending upon the video standard selected. The total range of the horizontal offset is $\pm\frac{1}{2}$ line.

Genlock Fine Horizontal Offset

Genlock Fine Horizontal sets the fine horizontal timing. These increments are in sub-clock-cycle units. The total range of the fine horizontal offset is $\pm\frac{1}{2}$ line.

Black Signals

There are at least two analog black outputs available from the rear panel. (If the SPG 422 is option 1, then there are six Analog Black outputs.) Configure each separately for standard, timing, and signal type. If the selected standard is different from the genlock input, the SPG 422 locks to the internal oscillator that is clock-locked to the genlock input. The timing offset range is ± 2 fields and $\pm 8\frac{1}{2}$ lines.

Bars Signals

The Bars BNC connector outputs serial digital component color bars in either the 525 or 625 standard. A timing shift of ± 1 field and $\pm 8\frac{1}{2}$ lines is available. It is not necessary that the Bars output and the genlock input be the same standard. If they are not the same standard, then the signal locks to the internal oscillator that is clock-locked to the genlock. Select all variables from the Bars signals menu.

Serial Black

The Serial Black signal is identical to the Serial Bars signal except the bars signal information has been stripped off and replaced with black. It takes its timing offset information directly from the Serial Bars signal.

Audio Signals

There are three different formats of Serial Audio signals available from the rear panel: AES/EBU from BNC connectors, AES/EBU from XLR connectors, and embedded audio in the Serial Digital Video signal. If any audio parameters change, then all of the audio outputs are affected. Different audio tones and levels are available for each channel. Up to four channels are available. Turn them on or off and change the tone and levels independently.

Although the output frequency and amplitudes are the same, the AES and embedded audio are essentially generated by separate generators. Therefore, there is no consistent phase relationship between the two with respect to audio tones. The digital audio sample frames are synchronized with the video frame. (For more information see page 3–20 in the *Reference* section .)

Serial Signals (Option 2 only)

If option 2 is not installed then these outputs are plugged. Both outputs have identical signals. There are a wide variety of signals from which to choose. The timing offset relative to the genlock is selectable. The standard is selectable and can be independent of the genlock standard. If the standard is different from the genlock, then it takes its timing from the internal oscillator that is clock-locked to the Genlock signal. Therefore, the signal will be clock-locked but not frame-locked to the Genlock reference signal.

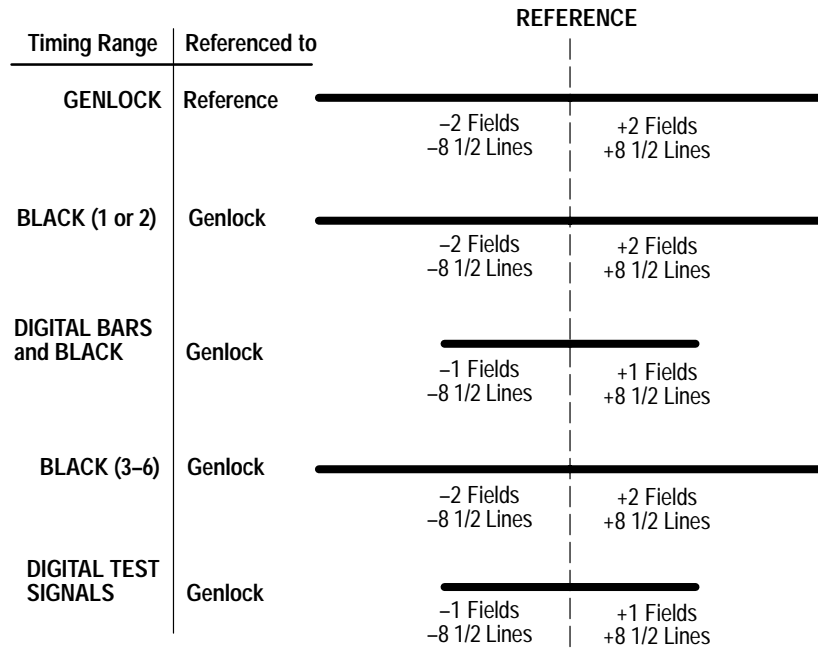

Figure 2-3: Illustration of the SPG 422 Timing



Reference

Reference

Using the Front Panel and Menu

The front-panel buttons and the Menu Display work together, providing you with a wide range of control, while keeping the front panel uncluttered.

The SPG 422 Menu Display is a two-line, 20-character-per-line LCD display. The SPG 422 displays messages corresponding to the position in the selected menus. The menus all have two lines of text, where the first line shows the current position in the current menu, and the second line shows a user message or the current selection (if there is not a submenu). If nothing is on the second line, press ENTER to get to the corresponding submenu.

NOTE. *In this section, the menu representations use Courier type to preserve display letter spacing.*

The menu discussion begins with the Main menu and then continues through the menus provided with each of the Select buttons.

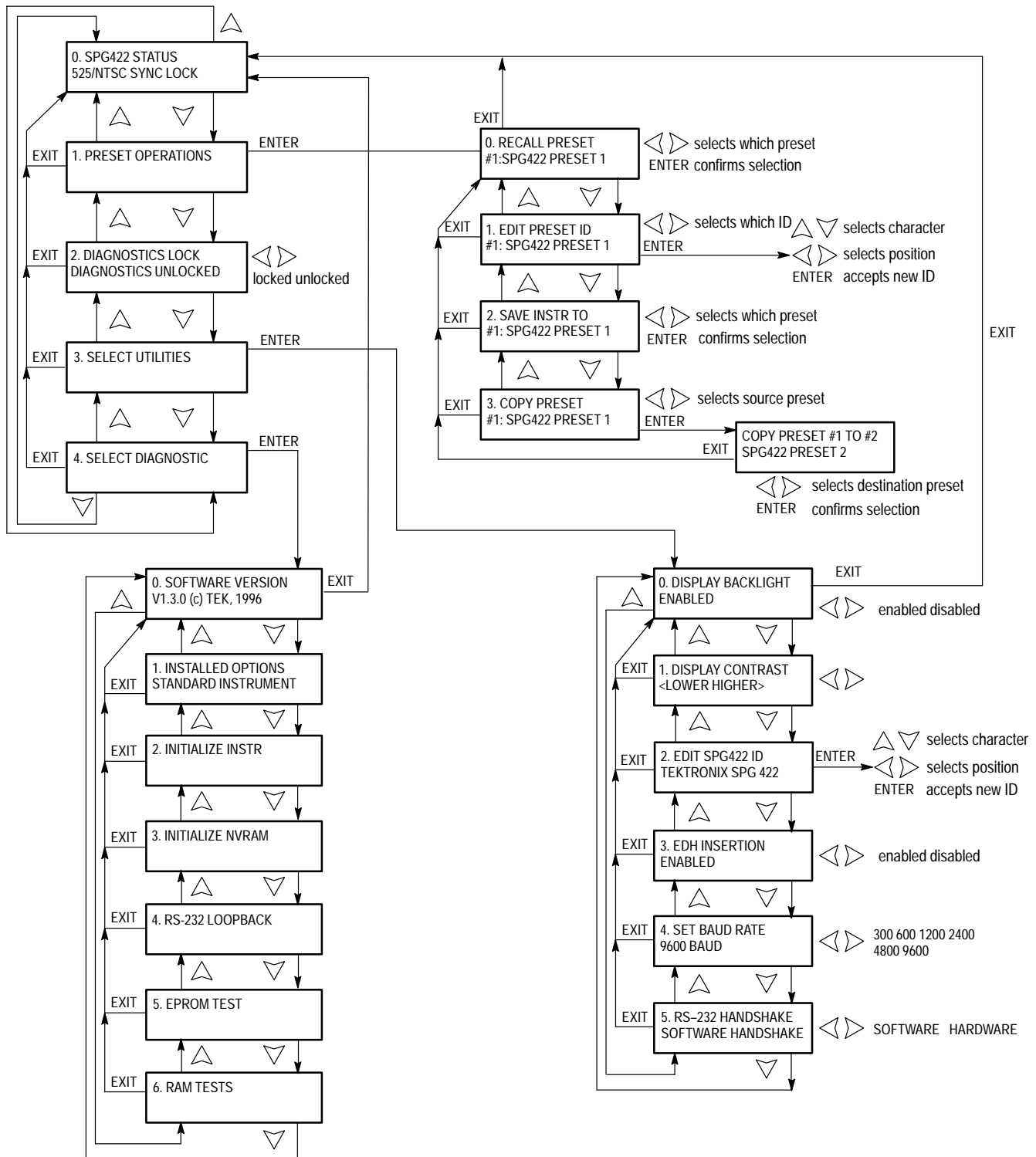

Figure 3-1: Illustration of the SPG422 Main Menu (V1.3.0)

Menus Available from the Main Menu

Main Menu This is the menu available when you do not select a Menu Select button. Pressing the up (▲) or down (▼) arrow button will scroll through the available Main Menu submenus. Figure 3–1 illustrates the structure of the Main Menu.

0. SPG 422 STATUS
INTERNAL

SPG 422 STATUS. This menu has no submenu or selections. It is the top of the Main menu. Repeatedly pressing the EXIT button will always return to this menu. The second line gives the genlock standard or status. If there is more information to display, the left (◀) or right (▶) arrow button lights. Use these buttons to view the additional information. Following the front-panel lockout time-out, the SPG 422 returns to the status menu.

The possible messages and actions if there are genlock errors are as follows:

REF SOURCE UNKNOWN	The genlock source is absent or incompatible. (Example: genlock signal is not connected). The instrument will automatically switch to internal and the external REF LED flashes.
REF LOCK ERROR	The genlock source is noisy.
REF FREQUENCY ERROR	The genlock frequency is outside its pull-in range.
REF LINE ERROR	The line length is incorrect. (Example: NTSC and PAL are swapped)
REF FIELD ERROR	Incorrect number of lines/field.
REF FRAME ERROR	Color frame error.
INT REF TEMP ERROR	Oscillator is outside its temperature range. (Example: needs more warm-up time or is overheating)

The possible messages if there are no genlock errors:

INTERNAL
PAL BURST LOCK
NTSC BURST LOCK
625/50 SYNC LOCK

525/59.94 SYNC LOCK
4.43 MHZ CW LOCK
3.58 MHZ CW LOCK
3.58 MHZ CW LOCK
1.00 MHZ CW LOCK
5.00 MHZ CW LOCK
10.00 MHZ CW LOCK

1. PRESET OPERATIONS

PRESET OPERATIONS. This menu is the access point to the Presets submenu. For the commands in the Presets submenu see page 3–5. The ENTER LED lights, indicating how to enter the Presets submenu.

2. DIAGNOSTICS LOCK
DIAGNOSTICS LOCKED

DIAGNOSTICS LOCK. This menu has no submenu. The second line is the current diagnostic lock status. If locked, you cannot execute any commands from the Diagnostic menu except the version and inventory queries. To change status, press the right (➡) or left (⬅) arrow button and the status changes immediately. The various options are:

DIAGNOSTICS LOCKED

DIAGNOSTICS UNLOCKED

3. SELECT UTILITIES

SELECT UTILITIES. This menu is the access point to the Utility submenu. For the commands in the Utility submenu see page 3–7. The ENTER LED lights, indicating how to get to the Utility submenu.

4. SELECT DIAGNOSTICS

SELECT DIAGNOSTICS. This menu is the access point to the Diagnostic submenu. For the commands in the Diagnostic submenu see page 3–9. The ENTER LED lights, indicating how to enter the Diagnostic submenu.

Presets Submenu

Presets is a submenu of the Main menu. To access these submenus, press ENTER when the Main menu has the Preset Operations option displayed. This menu contains assorted control commands not used on a regular basis. Pressing EXIT will return you to the Main menu.

0. RECALL PRESET
 #1: SPG422 PRESET 1

RECALL PRESETS. This menu has no submenu. The second line is the preset number and Preset identification string (see EDIT PRESET ID). Use the left (◀) or right (▶) arrow button to select a different preset. After you make a change, the ENTER LED lights to remind you to press ENTER to implement the selection. After pressing ENTER, the selected preset is loaded. Any changes you made affect the instrument. The various default options are:

```
#1: SPG422 PRESET 1
#2: SPG422 PRESET 2
#3: SPG422 PRESET 3
#4: SPG422 PRESET 4
```

The response message for this menu (after pressing ENTER) is:

RECALLING PRESET #1

RECALLING PRESET #1
 LOADING BAR SIGNALS

RECALLING PRESET #1
 LOADING TEST SIGNALS

```

RECALLING PRESET #1
LOADING AES AUDIO
    
```

```

RECALLING PRESET #1
LOAD EMBEDDED AUDIO
    
```

```

1. EDIT PRESET ID
#1: SPG422 PRESET 1
    
```

EDIT PRESET ID. This menu has the EDIT PRESET ID submenu. The second line is the current preset ID string. The LED on the ENTER button lights, indicating how to get to the ID submenu. Pressing ENTER begins editing the ID string. This submenu allows you to define and edit a 16-character ID string for the current preset. Use the left (◀) or right (▶) arrow button to select which character to modify. Use the up (▲) or down (▼) arrow button to choose the new character. Press ENTER to save the edited string. Press EXIT to leave this submenu without saving any changes.

```

2. SAVE INSTR TO #1
   SPG422 PRESET 1
    
```

SAVE INSTR TO. This menu has no submenu. This menu is used to save the current instrument settings to one of the four presets. When you first enter the menu, the second line shows the the preset ID string, which is the default destination preset. Use the left (◀) or right (▶) arrow button to select the destination preset. The ENTER key accepts the choice for destination preset. The response message for this menu is:

```

SAVING INSTR TO #1
   SPG422 PRESET 1
    
```

```

3. COPY PRESET
#1: SPG422 PRESET 1
    
```

COPY PRESET. This menu has no submenu. This menu allows you to copy one instrument preset into another (but not onto itself). When first entering the menu, the second line is the preset ID string, the default source preset. Use the left (◀) or right (▶) arrow button to select the source preset. The ENTER key accepts the choice for source preset. The response message for this menu is:

```

COPY PRESET #1 TO
#2: SPG422 PRESET 2
    
```

Then use the left (◀) or right (▶) arrow button to select the destination preset. Press ENTER to accept your choice for the destination preset. The display then responds with:

```
COPY PRESET
COPYING PRESETS 1 ->2
```

Utility Submenu

Utility is a submenu of the Main menu. To access these submenus, press ENTER when the Main menu has the Utility submenu option displayed. This menu contains assorted control commands not used on a regular basis. Press EXIT to return to the Main menu.

```
0. DISPLAY BACKLIGHT
ENABLED
```

DISPLAY BACKLIGHT. This menu has no submenu. This menu turns the backlight of the Menu Display on or off. Enabled turns the backlight on, disabled turns it off. When the Menu Display is not in use, turn the backlight off for applications where the backlight may be so bright that it is distracting.

```
1. DISPLAY CONTRAST
< LOWER HIGHER >
```

DISPLAY CONTRAST. This menu has no submenu. This menu allows you to adjust the contrast for the current viewing background light and angle. The second line explains how to adjust the Menu Display contrast. Use the left (◀) arrow button to reduce the amount of contrast. Use the right (▶) arrow button to increase the amount of contrast. The contrast value wraps around, so when the maximum value is reached the next value is the minimum value.

```
2. EDIT SPG422 ID
SPG422 ID STRING
```

EDIT SPG422 ID. This menu has the EDIT ID submenu. The second line is the current instrument ID string. This ID is the name for the instrument. The Menu Display shows the ID at power-up and is the ID available when using the remote.

The LED on the ENTER button lights, indicating how to enter the ID submenu. This submenu allows you to define and edit a 16-character instrument ID string. Use the left (◀) or right (▶) arrow button to select the character to modify. Use the up (▲) or down (▼) arrow button to choose the new character. Use the ENTER key to save the edited string. Use the EXIT button to leave this submenu without saving any changes.

Pressing EXIT will stop the copying procedure without making any changes. (Basically you are copying the current preset information to the preset number selected on the second line.)

```
3. EDH INSERTION
ENABLED
```

EDH INSERTION. This menu has no submenu. The second line is the current Error Detection and Handling insertion status. This menu allows you to enable or disable the generation and insertion of Error Detection and CRCs on all of the serial digital video signals. Use the right (▶) or left (◀) arrow button to turn CRCs on or off. Select from the following options:

```
ENABLED
DISABLED
```

```
4. SET BAUD RATE
9600 BAUD
```

SET BAUD RATE. This menu has no submenu. The second line is the current baud rate for the RS-232 remote control. This menu allows you to select between the available baud rates. Use the right (▶) or left (◀) arrows to select the baud rate. This command is only available from the front panel. Select from the following options:

```
300 BAUD
600 BAUD
1200 BAUD
2400 BAUD
4800 BAUD
9600 BAUD
```

```
7. RS-232 HANDSHAKE
HARDWARE HANDSHAKE
```

RS-232 HANDSHAKE. This menu has no submenu. The second line shows the current Handshake mode. This menu allows you to select between hardware and software Handshake control. Use the right (▶) or left (◀) arrow button to switch between the two modes:

SOFTWARE HANDSHAKE

HARDWARE HANDSHAKE

Handshake control changes immediately.

Diagnostic Submenu

Access this submenu from the Diagnostic command line on the Main menu. Enter this submenu by pressing ENTER. Leave this submenu and return to the Main menu by pressing EXIT. If the diagnostics are locked out, only the software version and installed option queries are available. (Unlock them using the Diagnostic Lock command on the Main menu.)

```
0. SOFTWARE VERSION
V1.3.0      © TEK,1996
```

SOFTWARE VERSION. This menu has no submenu. The second line is a string representing the current software version number.

```
1. INSTALLED OPTIONS
STANDARD INSTRUMENT
```

INSTALLED OPTIONS. This menu has no submenu. The second line is a string representing the options currently installed in the instrument. The list of currently available responses is:

```
STANDARD INSTRUMENT
OPTION 1 INSTALLED
OPTION 2 INSTALLED
OPTIONS 1 AND 2
```

```
2. INITIALIZE INSTR
```

INITIALIZE INSTR. This menu has no submenu. This menu allows you to initialize the SPG422 back to its original, factory, settings.

After pressing ENTER, this message is displayed:

```
INIT INST TO
NTSC
```

The options are NTSC or PAL. Use the arrow buttons to make a selection. After making a selection and pressing ENTER, the Menu Displays the response message.

```
INSTRUMENT INITIALIZ
```

```
INSTRUMENT INITIALIZ  
LOADING BARS SIGNAL
```

```
INSTRUMENT INITIALIZ  
LOADING TEST SIGNALS
```

```
INSTRUMENT INITIALIZ  
LOADING AES AUDIO
```

```
INSTRUMENT INITIALIZ  
LOAD EMBEDDED AUDIO
```

If you choose to not initialize the instrument, pressing EXIT will return you to the Main menu without making any changes.

```
3. INITIALIZE NVRAM
```

INITIALIZE NVRAM. This menu has no submenu. The LED on the ENTER button lights, indicating how to select the initialize NVRAM function.



CAUTION. *When you initialize the NVRAM, it overwrites all data currently in the NVRAM. Use this command with discretion.*

```
3. INITIALIZE NVRAM  
ENTER TO CONTINUE
```

Press ENTER if you are sure you want to continue the operation. The response messages for this menu are:

```
3. INITIALIZE NVRAM
TESTING NVRAM
```

```
3. INITIALIZE NVRAM
INITIALIZING NVRAM
```

```
TEKTRONIX SPG 422
```

```
TEKTRONIX SPG 422
LOADING BARS SIGNALS
```

```
TEKTRONIX SPG 422
LOADING TEST SIGNALS
```

```
TEKTRONIX SPG 422
LOADING AES AUDIO
```

```
TEKTRONIX SPG 422
LOADING AUDIO DATA
```

When the initialization is complete, the Menu Display returns to the top of the Main menu.

```
4. RS-232 LOOPBACK
```

RS-232 LOOPBACK. This menu has no submenu. The LED on the ENTER button lights, indicating how to select the loopback diagnostic. This routine allows you to attach an RS-232 loopback plug to the Remote output connector and verify that the RS-232 transmit and receive functions are working. The menu displays the following while the RS-232 test is operating:

```
4. RS-232 LOOPBACK
```

The available response messages are as follows:

```
LOOPBACK TEST PASSED
```

```
LOOPBACK TEST FAILED
```

5. EPROM TEST

EPROM TEST. This menu has no submenu. The ENTER LED lights, indicating how to select the EPROM diagnostic. This routine allows you to run the EPROM checksum test to verify that the EPROM contents are intact. After pressing ENTER, the following message appears:

5. EPROM TEST
TESTING CHECKSUMS

Once the test is completed, the display changes:

EPROM U10 TEST *RESULT*
EPROM U11 TEST *RESULT*

EPROM U10 and EPROM U11 are located on the A2 Digital board.

The *TEST RESULT* messages will read one of two ways:

TEST PASSED
TEST FAILED

6. RAM TESTS

RAM TESTS. This menu has no submenu. The second line is the diagnostic message. This routine allows you to run the RAM Test to verify that the processor RAM and the RAMs in the audio and video generators are functional. Press ENTER to run the RAM Test. The following messages appear:

6. RAM TEST
TESTING STATIC RAMS

TEKTRONIX SPG422

TEKTRONIX SPG422
LOADING BARS SIGNALS

```
TEKTRONIX SPG422  
LOADING TEST SIGNALS
```

```
TEKTRONIX SPG422  
LOADING AES AUDIO
```

```
TEKTRONIX SPG422  
LOADING AUDIO DATA
```

The available response messages are:

```
ALL RAM TESTS PASSED
```

```
AUDIO RAM FAILED
```

```
BARS RAM FAILED
```

```
EMBEDDED RAM FAILED
```

```
TEST RAM FAILED
```

Menus Available from the Select Buttons

The following menus are available from the select buttons. To enter a Select Button menu, press the desired select button. To leave a Select Button menu and return to the Main menu, press EXIT. Figure 3–2 illustrates this concept.

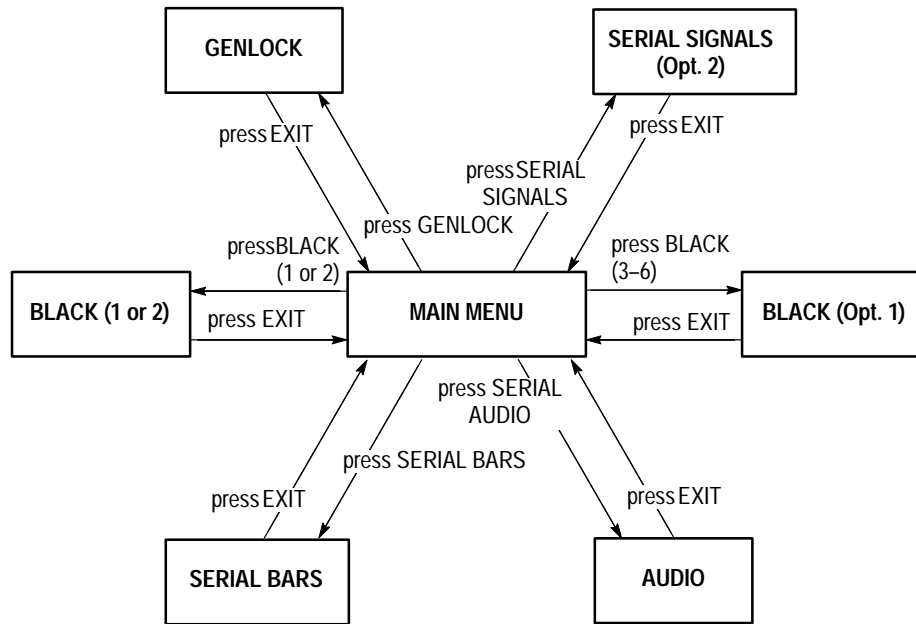

Figure 3-2: How the Menus are Accessed Using the Select Buttons and Their Relationship to the Main Menu

Genlock Menu

Select the **GENLOCK** button to bring up the Genlock menu. Return to the Main menu by pressing EXIT. Use the up (▲) or down (▼) arrow button to scroll through the Genlock menu choices. Figure 3-3 illustrates the Genlock menu structure.

```

0. GENLOCK MODE
NTSC BURST LOCK
  
```

GENLOCK MODE. This menu has no submenu. The second line is the current genlock mode selection. Select the genlock mode using the left (◀) or right (▶) arrow button. The change takes place when you leave this menu (scroll up or down). The options are:

- INTERNAL
- PAL BURST LOCK
- NTSC BURST LOCK
- 625/50 SYNC LOCK
- 525/59.94 SYNC LOCK
- 4.43 MHZ CW LOCK

- 3.58 MHZ CW LOCK
- 1.00 MHZ CW LOCK
- 5.00 MHZ CW LOCK
- 10.00 MHZ CW LOCK

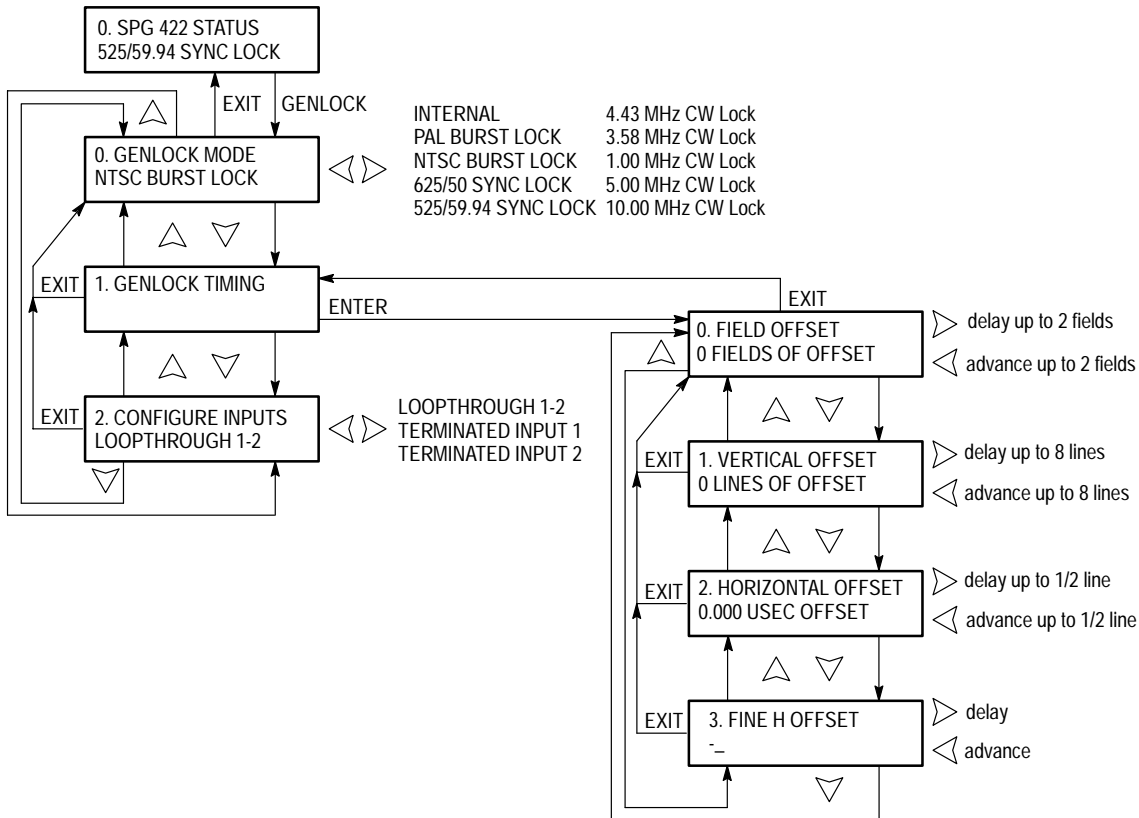
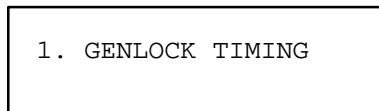

Figure 3-3: The Genlock Menu Structure



GENLOCK TIMING. This menu is the Timing submenu. The LED on the ENTER button lights, indicating how to get to the submenu. This menu allows you to adjust the timing of all outputs relative to the genlock source. The Genlock Timing submenu is essentially the same as any other Timing submenu. For the discussion of the Timing submenu, see page 3-28.

```
2. CONFIGURE INPUTS
LOOP-THROUGH 1-2
```

CONFIGURE INPUTS. This menu has no submenu. This menu allows you to configure and select the genlock input connections. The second line is the current input configuration. Use the right (➡) or left (⬅) arrow button to select from the following options. In the terminate options, both genlock inputs are terminated, but only the selected one is used. The options are:

```
LOOP-THROUGH 1-2
TERMINATED INPUT 1
TERMINATED INPUT 2
```

Serial Bars Menu

Enter this menu by pressing the **SERIAL BARS** select button. It allows selection of the Serial Bars signal and the timing associated with it. Pressing EXIT leaves this menu and returns to the Main menu. Figure 3–4 illustrates the Serial Bars menu structure.

```
0. SELECT SIGNAL
SMPTE COLOR BARS
```

SELECT BARS. This menu has no submenu. The second line is the current bars signal selection. This menu allows you to select the bars output test signal using the left (⬅) or right (➡) arrow button. Changes do not occur until the ENTER button confirms the change and loads the new signal. Select from the signals below:

```
SMPTE COLOR BARS (525 only)
75% BARS OVER RED (625 only)
100% BARS OVER RED (625 only)
75% COLOR BARS
100% COLOR BARS
SERIAL BLACK
```

```
0. SELECT SIGNAL
NEW SIGNAL SELECTED
```

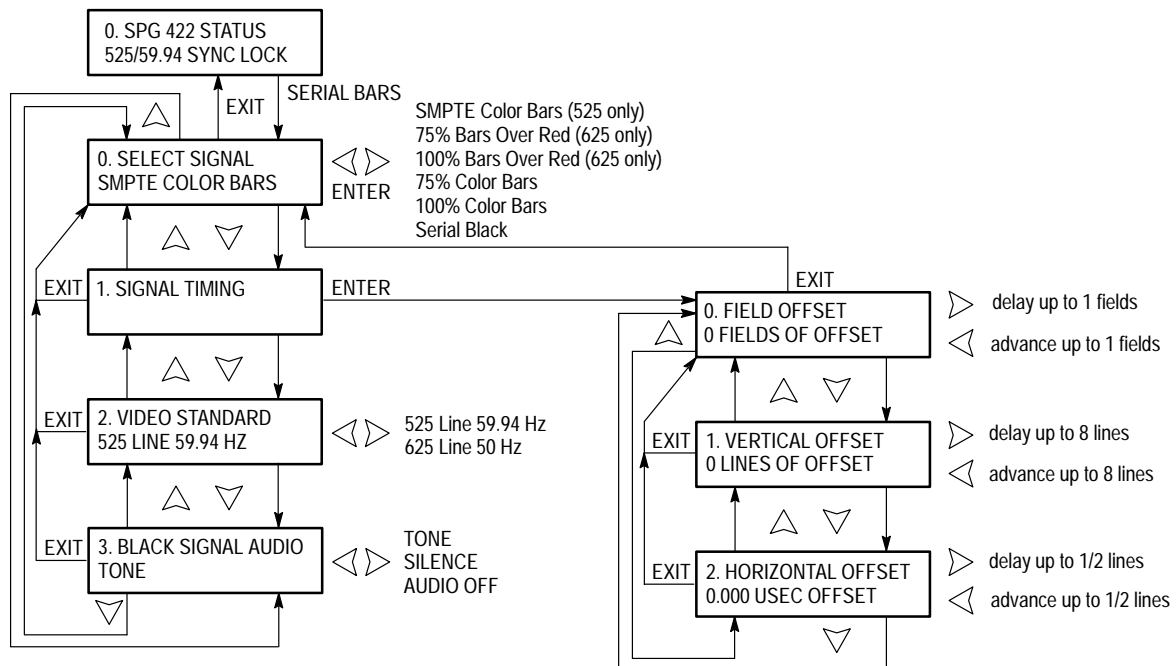

Figure 3-4: The Serial Bars Menu Structure

1. SIGNAL TIMING

SIGNAL TIMING. This menu is the timing submenu. The LED on the ENTER button lights, indicating how to get to the submenu. This menu allows you to move the timing of the serial bars and serial black outputs relative to the genlock.

For more information on the Timing submenus, See *Timing Menu* on page 3-28.

2. VIDEO STANDARD
525 LINE 59.94 HZ

VIDEO STANDARD. This menu has no submenu. The second line is the current video standard. This menu allows you to choose between the 525/59.94 and 625/50 video standards for the serial bars and serial black outputs. Press ENTER to initiate a change and load the new data.

2. VIDEO STANDARD
LOADING BARS SIGNALS

You have two options:

525 LINE 59.94 HZ

625 LINE 50 HZ

3. BLACK SIGNAL AUDIO
TONE

BLACK SIGNAL AUDIO. This menu has no submenu. The second line is the current selection of the embedded audio mode. The menu allows you to choose between AUDIO OFF, SILENCE, and TONE. This affects the serial black output only, and not the serial bars output. The change takes place when you leave this menu (scroll up or down).

You have three BLACK SIGNAL AUDIO options:

AUDIO OFF: No audio in serial black signal

SILENCE: A 0 Hz tone is embedded in the serial black output.

TONE: The tone selected in the Serial Audio menu is embedded in the serial black output.

If the second line reads EMB AUDIO DISABLED, then embedded audio has been disabled in the Serial Audio menu. You must enable the embedded audio before you can make any selections in this menu.

Serial Audio Menu

Access this menu by pressing the SERIAL AUDIO button. It allows you to set up the AES/EBU serial audio signal. First, select which channel(s) should have an audio signal. Then select the frequency and the amplitude of the tone. Also select the number of bits (either 20 or 24) and information about embedded audio on the serial digital video signal. Pressing EXIT returns you to the Main menu. Figure 3–5 illustrates the structure of the Serial Audio menu.

0. SET FREQ & LVL ON
ALL AUDIO CHANNELS

SET FREQUENCY and LEVEL ON. This menu does have a submenu (the ENTER LED is lit indicating how to get to the submenu). The second line shows the current channel selection. Use the right (▶) or left (◀) arrow button to scroll through the choices. This menu allows you to select the channel(s) to vary the frequency and level (from its submenu). Select from the options below:

AUDIO CHANNEL 1 ONLY

AUDIO CHANNEL 2 ONLY

AUDIO CHANNEL 3 ONLY

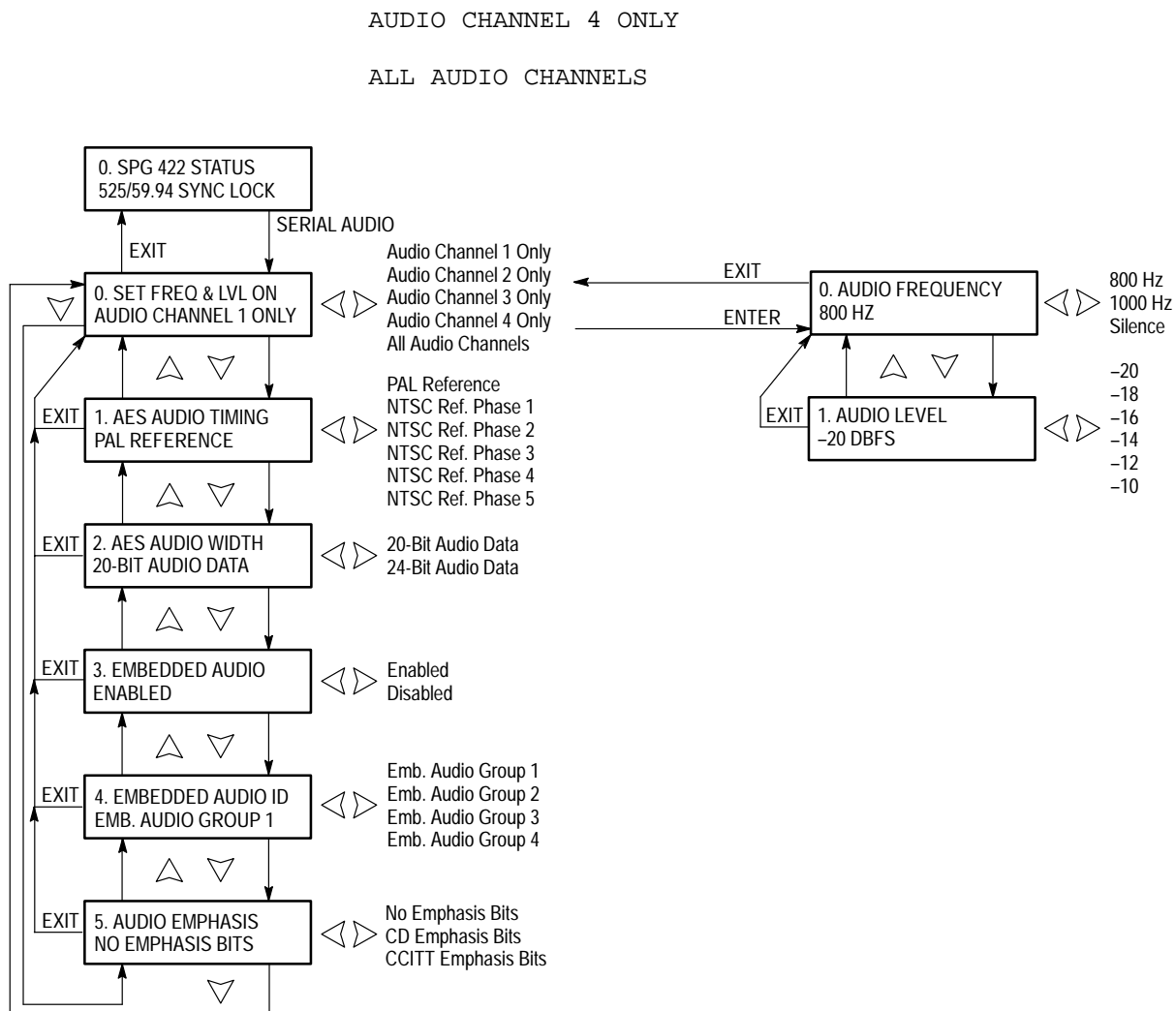

Figure 3-5: The Serial Audio Menu

After the channel has been selected, pressing ENTER confirms the choice and enters the Audio Level and Frequency submenu. See page 3-22 for an explanation of the Audio Level and Frequency submenu.

```
1. AES AUDIO TIMING
PAL REFERENCE
```

AUDIO TIMING. This menu has no submenu. The second line is the current audio timing reference. This menu allows you to move the timing of the AES/EBU outputs relative to the video genlock source. The options are:

PAL REFERENCE

NTSC REF. PHASE 1

NTSC REF. PHASE 2

NTSC REF. PHASE 3

NTSC REF. PHASE 4

NTSC REF. PHASE 5

This timing is with respect to the Genlock timing; therefore, leave one of the Black signals with zero timing change and use it as the reference for the audio signals. For further details on Audio Timing, continue reading below; otherwise, skip to the *SERIAL AUDIO WIDTH* discussion on page 3–21.

The SPG 422 uses an internal video reference that may be genlocked to an external source with adjustable advance or delay. The AES/EBU digital audio is phase locked to that internal reference and follows its timing adjustment. Digital and black burst output signals may be further adjusted with advance or delay with respect to the internal reference. Therefore the black burst to digital audio phasing will be at the nominal (proposed standard) value only when the black burst timing is set to zero (no advance or delay).

The proposed requirement for PAL audio timing is defined in EBU draft recommendation R199 (12/1991) and requires that the start of the X (or Z) preamble be within $\pm 1.04 \mu\text{sec}$ (5% of an audio sample) of the 50% point of the leading edge of sync on field 1 line 1. This only accounts for audio frame timing, and audio block timing is explicitly disregarded. Since there is an integer number of audio samples (hence digital audio frames) in each video frame, there is only one possible nominal phase of digital audio with respect to video.

The requirement for NTSC audio timing is more complicated because of the NTSC frame rate. SMPTE proposed recommended practice S17.401 specifies a timing requirement that the start of the audio frame be within $\pm 1 \mu\text{sec}$ of the 50% point of the leading edge of the first equalizer on field 1 line 1. Audio block timing is not addressed. The NTSC audio timing only occurs once every five video frames due to the non-integer number of audio samples per video frame. Since there is no five-frame reference information in the video, there are five possible phases of digital audio relative to video. The menu allows for selection of one of the five phases.

Digital audio to video timing is straightforward with one audio signal and one video signal and an optional genlock input signal of the same line standard. Since there can be as many as six black burst outputs, the digital audio will be correctly phased only with those outputs that have zero timing offset or whose timing offset is within the phasing tolerance of the proposed standard. Again the black burst signals must be of the same line standard as the genlock input signal, if any.

In the case where the black burst signal is of a different line standard than the genlock input, there is no specified phase relation between the AES/EBU digital audio out and that black burst. With no genlock input, the digital audio will be correctly phased with black burst signals of the line standard (PAL or NTSC) selected in the AES Audio Timing menu (recognizing the limitations stated above).

```
2. AES AUDIO WIDTH
20-BIT AUDIO DATA
```

SERIAL AUDIO WIDTH. This menu has no submenu. This menu allows you to select the resolution of the serial digital audio signal data. The second line is the current AES/EBU serial audio sample data width. Change between the two options using the right (▶) or left (◀) arrow button. Note that this selection affects all serial audio outputs. If a new option is selected, the ENTER LED flashes to indicate then the ENTER button must be pressed to confirm the choice and load the new data. When ENTER is pressed the following messages appear:

```
2. AES AUDIO WIDTH
LOADING AES AUDIO
```

```
2. AES AUDIO WIDTH
LOADING AUDIO DATA
```

The available options are:

20-BIT AUDIO DATA

24-BIT AUDIO DATA

```
3. EMBEDDED AUDIO
ENABLED
```

EMBEDDED AUDIO. This menu has no submenu. The second line is the current embedded audio insertion status. This menu allows you to enable or disable the generation and insertion of embedded audio on the serial digital video outputs. The frequency and levels of the embedded audio signal are the same as the serial audio signal. Use the right (▶) or left (◀) arrow button to change between enabled and disabled. This command has no effect on the Serial Audio outputs. Select from the following options:

ENABLED

DISABLED

4. EMBEDDED AUDIO ID
EMB. AUDIO GROUP 1

EMBEDDED AUDIO ID. This menu has no submenu. The second line is the current embedded audio group ID. The audio group ID defines which 4 of the 16 possible channels are embedded in the serial digital video signal. Use the left (◀) or right (▶) arrow button to make the selection. Note that this selection affects all serial video outputs. Select from the options below:

- EMB. AUDIO GROUP 1 (Channels 1 – 4 are embedded in the video signal)
- EMB. AUDIO GROUP 2 (Channels 5 – 8 are embedded in the video signal)
- EMB. AUDIO GROUP 3 (Channels 9 – 12 are embedded in the video signal)
- EMB. AUDIO GROUP 4 (Channels 13 – 16 are embedded in the video signal)

5. AUDIO EMPHASIS
NO EMPHASIS BITS

AUDIO EMPHASIS. This menu has no submenu. The second line is the current setting of the audio emphasis bits. This menu allows you to select the state of the audio emphasis bits. (There is never emphasis on the audio signal. This option only sets the status bits.) Use the right (▶) or left (◀) arrow button to select the emphasis. Note that this selection affects all serial audio and embedded audio outputs. Select from the options below:

- NO EMPHASIS BITS
- CD EMPHASIS BITS
- CCITT EMPHASIS BITS

The ENTER button lights if a new option is selected, to remind you to press ENTER to confirm the choice and load the new data. When ENTER is pressed, the following messages appear:

5. AUDIO EMPHASIS
LOADING AES AUDIO

5. AUDIO EMPHASIS
LOADING AUDIO DATA

AUDIO LEVEL AND FREQUENCY SUBMENU. You enter this submenu from the SET FREQ & LVL ON menu and it only affects the channels selected there.

```
0. AUDIO FREQUENCY
800 HZ
```

AUDIO FREQUENCY. This menu has no submenu. The second line is the audio tone frequency for the currently selected channel(s). This menu allows you to select the audio signal frequency using the left (◀) or right (▶) arrow button. Remember, any change only affects the channel(s) selected before entering this submenu. Pressing EXIT returns you to SET FREQ & LVL ON menu. Select from the options below:

```
800 HZ
1000 HZ
SILENCE
```

If the option changes from the current selection the ENTER LED lights, reminding you to press the ENTER button to confirm the choice and load the new data. When the ENTER button is pressed, the following messages appear:

```
0. AUDIO FREQUENCY
LOADING AES AUDIO
```

```
0. AUDIO FREQUENCY
LOADING AUDIO DATA
```

```
1. AUDIO LEVEL
-20 DBFS
```

AUDIO LEVEL. This menu has no submenu. The second line is the current audio tone amplitude for the currently selected audio channel(s). This menu allows you to select the audio signal amplitude (in dB below digital full-scale) using the left (◀) or right (▶) arrow button. Remember, any change only affects the channel(s) selected with the SET FREQ & LVL ON command. Select from the options below:

```
-20 DBFS
-18 DBFS
-16 DBFS
-14 DBFS
-12 DBFS
-10 DBFS
```

If silence is selected as the audio frequency, then the Audio Level menu only states Silence has 0 Ampl.

If the option changes from the current selection the ENTER LED lights, reminding you to press the ENTER button to confirm the choice and load the new data. When the ENTER button is pressed, the following message appears:

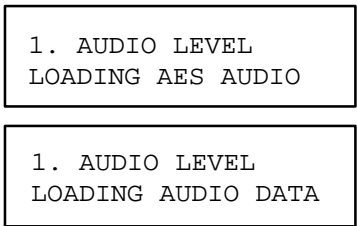

Black Menus

Menus similar to these access the various Analog Black signal menus—the Black button selects which Black output. Blacks 1 and 2 are available on all instruments. Blacks 3 through 6 are only available on instruments with option 1 installed. These menu cover the type of black signal and timing available from the corresponding black BNC connector on the rear panel. Pressing EXIT returns you to the Main menu. Figure 3–6 illustrates Black 1 and 2 menu structure, while Figure 3–7 illustrates Blacks 3 through 6 menu structure.

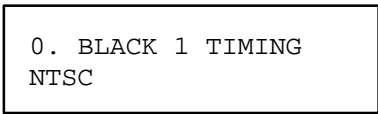

BLACK TIMING. This menu has the Timing submenu. The ENTER LED lights, indicating how to get to the Black Timing submenu. This menu allows you to move the timing of the selected black signal output relative to the genlock. The second line shows the current video standard selected. For more information on the Black Timing submenu, please see Timing Sub menu on page 3–30.

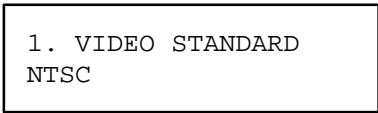

VIDEO STANDARD. This menu has no submenu. The second line is the current video standard. It allows you to select between NTSC and PAL as the video standard for the black signal output. Use the left (◀) or right (▶) arrow button to select between the two.

- NTSC
- PAL

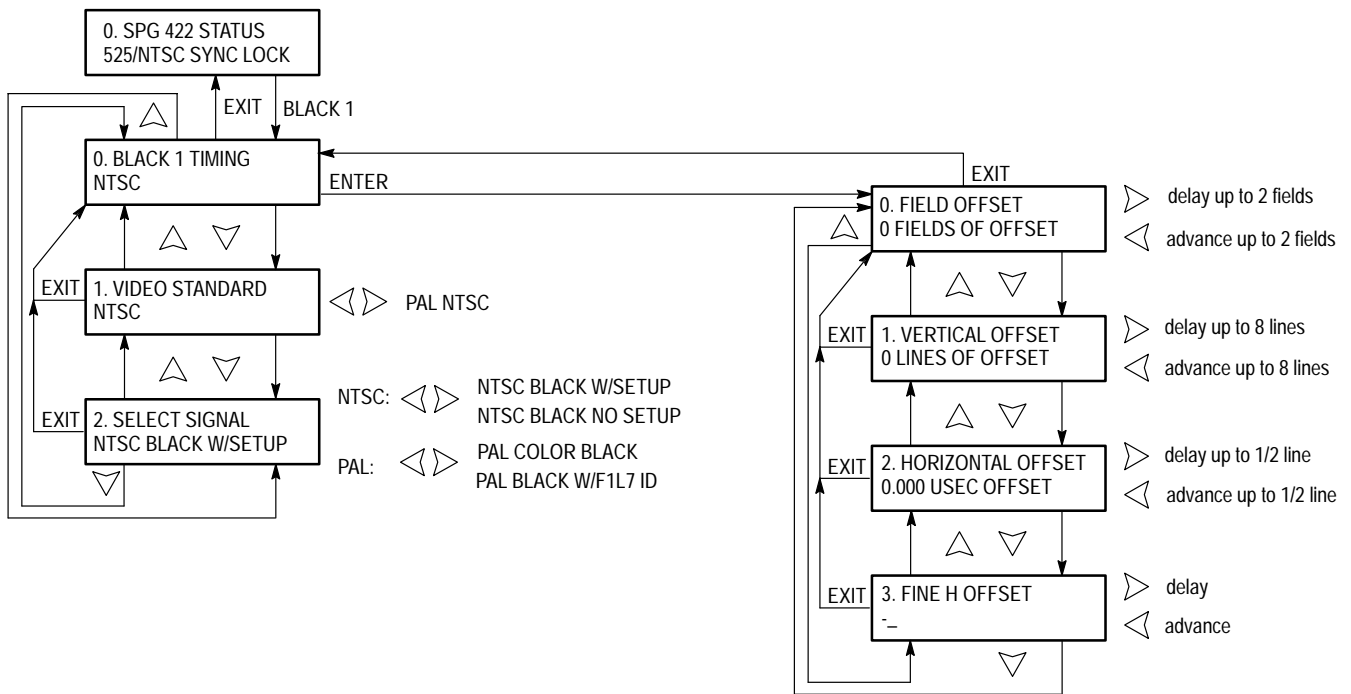

Figure 3-6: Black 1 and 2 Menu Structure

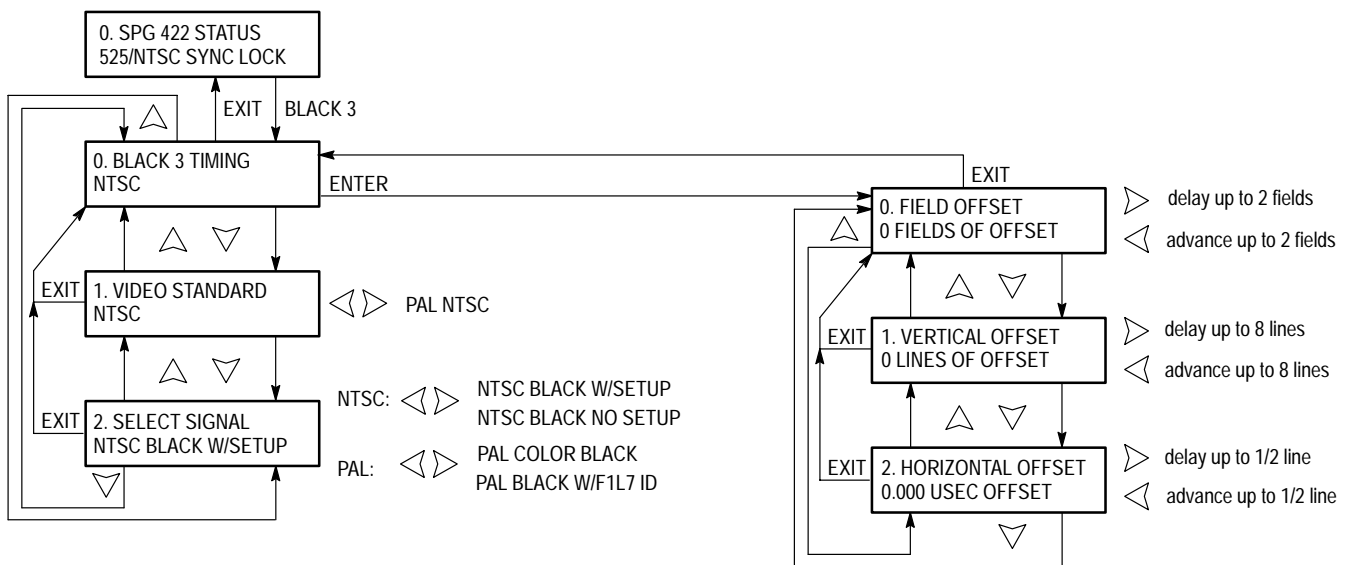

Figure 3-7: Black 3 through 6 Menu Structure

```

2. SELECT SIGNAL
NTSC BLACK W/ SETUP
    
```

SELECT SIGNAL. This menu has no submenu. The second line is the current black signal. This menu allows you to select the black signal (valid for the video standard) using the left (◀) or right (▶) arrow button. Select from the following options:

- NTSC BLACK W/ SETUP
- NTSC BLACK NO SETUP
- PAL COLOR BLACK
- PAL BLACK W/ F1L7 ID

Serial Signals Menu

These signals are only available if option 2 is installed. This menu selects the serial digital video signal available at the Serial signal BNC connectors on the rear panel. It also selects the timing relative to the genlock and the standard (525 or 625). Pressing EXIT returns to the Main menu. Figure 3–8 illustrates the menu structure for the Serial signals.

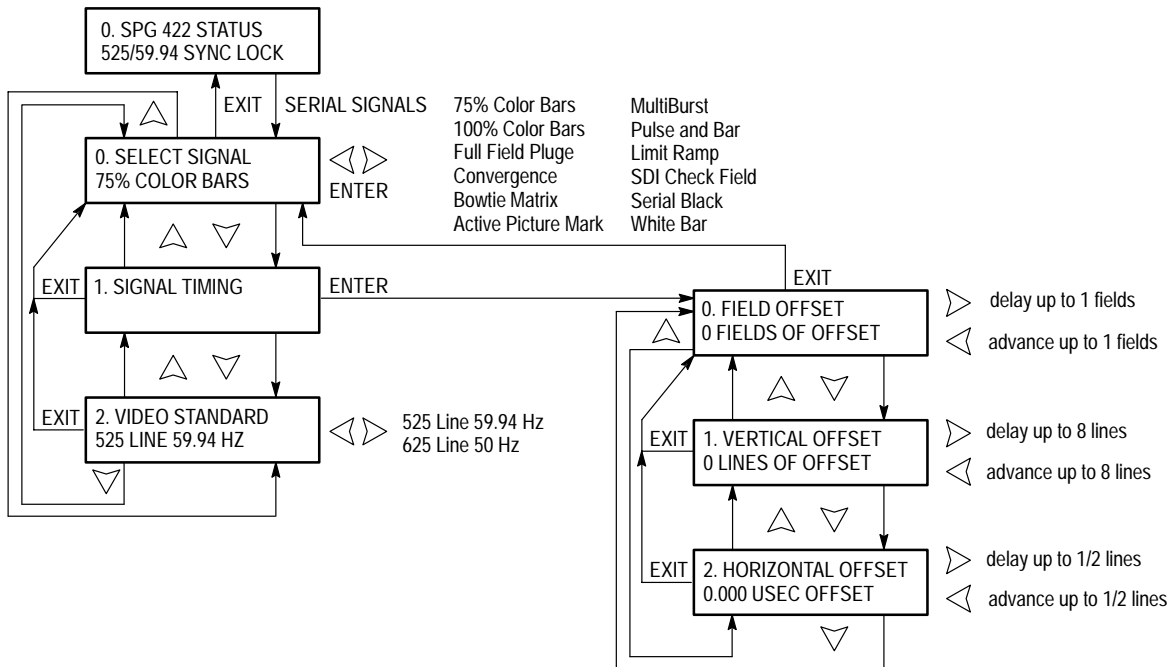

Figure 3–8: The Serial Signals Menu Structure

```
0. SELECT SIGNAL
SMPTE COLOR BARS
```

SELECT SIGNAL. This menu has no submenu. The second line is the current serial signal selection. This menu allows selection of the serial signal output using the left (◀) or right (▶) arrow button. Press the ENTER button to accept any changes and load the new signal. After pressing ENTER, the follow message appears:

```
0. SELECT SIGNAL
NEW SIGNAL SELECTED
```

The available signals are:

```
75% COLOR BARS
100% COLOR BARS
FULL FIELD PLUGE
CONVERGENCE
BOWTIE MATRIX
ACTIVE PICTURE MARKER
MULTIBURST
PULSE AND BAR
LIMIT RAMP
SDI CHECK FIELD
SERIAL BLACK
WHITE BAR
```

```
1. SIGNAL TIMING
```

SIGNAL TIMING. This menu has the Timing submenu. The LED on the ENTER button lights, indicating how to get to the Serial signal submenu. This menu allows you to move the timing of the serial signal outputs relative to the genlock.

For more information on the Black Timing submenu, please see Timing submenu discussion, below.

```
2. VIDEO STANDARD
525 LINE 59.94 HZ
```

VIDEO STANDARD. This menu has no submenu. The second line shows the current video standard. This menu allows you to select between the 525/59.94 and 625/50 video standards for the serial signal outputs. Use the right (▶) or left (◀) arrow button to select between the two standards. Press ENTER to confirm the change and load the new signal. When ENTER is pressed the following message appears:

```
2. VIDEO STANDARD
LOADING TEST SIGNALS
```

Select from the following:

- 525 LINE / 59.94 HZ
- 625 LINE / 50 HZ

Timing Submenu

The Timing submenu is very similar in all of its occurrences. It allows the timing of the output signal to shift relative to the genlock signal. The ENTER button never needs to be pressed to accept a choice in this submenu—all changes take place immediately. Press ENTER to enter this submenu. EXIT returns to the starting menu.

```
0. FIELD OFFSET
0 FIELDS OF OFFSET
```

FIELD OFFSET. This menu has no submenu. The second line is the current field timing offset. This command allows you to move the selected output timing (or genlock timing) in field increments, relative to the genlock, using the left (◀) or right (▶) arrow button. The options are:

- 2 FIELDS OF ADVANCE
- 1 FIELD OF ADVANCE
- 0 FIELDS OF OFFSET
- 1 FIELD OF DELAY
- 2 FIELDS OF DELAY

```
1. VERTICAL OFFSET
0 LINES OF OFFSET
```

VERTICAL OFFSET. This menu has no submenu. The second line is the current vertical timing offset. This allows you to move the timing in video line increments, relative to the genlock. The left (◀) or right (▶) arrow button scrolls through the choices. The choices are:

```
8 LINES OF ADVANCE
7 LINES OF ADVANCE
6 LINES OF ADVANCE
5 LINES OF ADVANCE
4 LINES OF ADVANCE
3 LINES OF ADVANCE
2 LINES OF ADVANCE
1 LINE OF ADVANCE
0 LINES OF OFFSET
1 LINE OF DELAY
2 LINES OF DELAY
3 LINES OF DELAY
4 LINES OF DELAY
5 LINES OF DELAY
6 LINES OF DELAY
7 LINES OF DELAY
8 LINES OF DELAY
```

```
2. HORIZONTAL OFFSET
0.000 USEC OFFSET
```

HORIZONTAL OFFSET. This menu has no submenu. The second line is the current horizontal timing offset. This command allows you to move the selected timing in clock-cycle increments, using the left (◀) or right (▶) arrow button.

```
3 . FINE H OFFSET
—
```

FINE HORIZONTAL OFFSET. This menu has no submenu and is only available from some menus. The second line changes from “—” to “|”, to indicated that the horizontal offset is changing. This routine allows you to move the selected timing in sub-clock-cycle increments, using the left (◀) or right (▶) arrow button. The total offset range is one clock-cycle.

Using the RS-232 Remote

Using the Parser The remote connector on the rear panel can be either a simple ground-closure remote or an RS-232 port. This section discusses the RS-232 configuration. (Set internal jumpers to select the configuration.)

Many of the commands that the SPG 422 front panel and menu generate are accessible using a dumb terminal and the Remote port. The following section explains how to install a terminal and how to use the commands.

Installation An RS-232 cable is needed to connect the Terminal port to the SPG 422 Remote port. Order a cable that will support both the terminal and the Remote port.

Use the following steps to set up for RS-232 remote use:

1. Use the front-panel menu to set the SPG 422 baud rate to 9600 (or whatever the terminal requires).
2. Disconnect the power from both the terminal and the SPG 422.
3. Attach the cable to the Terminal RS-232 port and to the SPG 422 Remote input, as shown in Figure 3–9.
4. Set the terminal baud rate to 9600 (or whatever is appropriate), eight bits, one stop bit, no parity, and ECHO REMOTE. (Use the instructions provided with the terminal to make these changes.)
5. Remove the top cover from the SPG 422.
6. If necessary, move the remote port cable to the connector labeled “RS-232”.

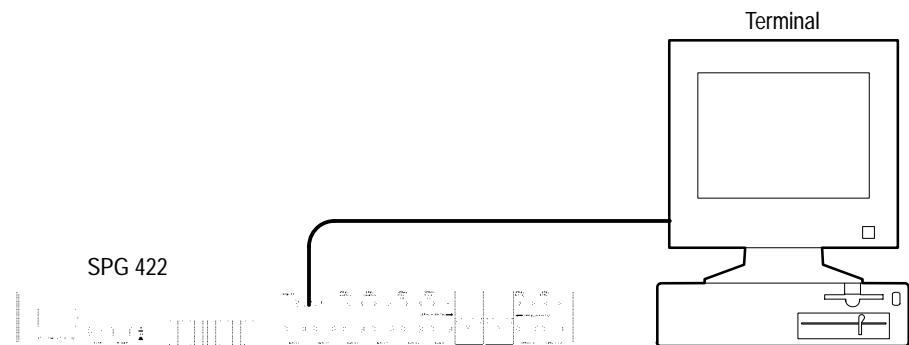

Figure 3–9: How to Connect the Terminal

7. Replace the top cover of the SPG 422.

8. Return power to both the terminal and the SPG 422.
9. When the terminal is ready, a prompt will appear on the terminal:

SPG422>

The Parser is now ready to accept commands.

The following pages give the Parser Tree, which is the hierarchy of the command strings.

The RS-232 Remote Control menu is as follows:

Square brackets ([]) enclose optional parameters.

RS-232 Command Summary

*RST			(reset instrument to factory default, but only after :SYST:SEC. Press RETURN after initialization)
*IDN?			(returns instrument SCPI ID)
:DIAGnostic			
	:LCDisplay		(runs display diagnostics and returns message)
	:FPLed	<value, value, value>	(writes configuration bytes to front-panel LEDs)
	:FPSWitch		(reads front-panel keyboard and returns scan code)
	:GENLock		(runs genlock diags and returns message. Press RETURN after test is complete)
	:MEMory		(runs memory diags and returns message. Reinitializes NVRAM to factory settings. Press RETURN after test is complete)
	:PREMote		(reads parallel remote port and returns value read)
	:SCLock	<ENA, DIS>	(Enables/disables GVG serializers to output only serial clock)
	:VCO	<numeric_value>	(sets VCO correction source to contrast DAC and write specified value to contrast DAC)
:DISPlay			
	:BACKlight	ENA DIS	(enable/disable display backlight)
	:BACKlight?		(returns ENA or DIS)
	:CONTrast	<numeric_value>	(1=down?...,254=up?)
	:CONTrast?		(returns contrast value)
:INPut			
	:CONFigure	TERM1 TERM2 LOOP12	
	:CONFigure?		(returns configuration)
	:STANdard	INT NBL PBL NSL PSL PCW NCW OCW FCW TCW	
	:STANdard?		(returns type)
	:FIEld	<numeric_value>	(-2 to 2 for 2 fields of advance to 2 fields of delay)
	:FIEld?		(returns fields of timing offset)
	:VERTical	<numeric_value>	(-8 to 8 for 8 lines of advance to 8 lines of delay)
	:VERTical?		(returns lines of timing offset)
	:HCOarse	<numeric_value>	(in integer clock-cycles for -32 to +32 μ sec offset)
	:HCOarse?		(returns coarse horizontal timing offset)
	:HFine	<numeric_value>	(0 to 255 for 0 to 90 degrees of clock phase)
	:HFine?		(returns fine horizontal timing offset)
:INPut?			(returns genlock status, configuration and timing offsets)
:OUTPut			
	:AUDio		
	:AWIDth	20BIT 24BIT	(serial audio data width)
	:AWIDth?		(returns audio width value)
	:AEMPhasis	NONE CD CCITT	
	:AEMPhasis?		(returns emphasis value)
	:EAUDio	ENA DIS	(enable or disable embedded audio insertion on all serial digital video outputs)
	:EAUDio?		(returns audio value)
	:EAGRoup	GROUP1 GROUP2 GROUP3 GROUP4	(embedded audio group ID)
	:EAGRoup?		(returns embedded audio group)
	:SIGNal	<channel, frequency, amplitude>	(where channel is in this list: 1, 2, 3, 4, ALL; frequency is in this list: 800HZ,1000HZ, Silence; and amplitude is in this list: -10DBFS, -12DBFS, -14DBFS, -16DBFS, -18DBFS, -20 DBFS)

	:SIGNal?		(returns channels, signals, and amplitudes)
	:TIMing	PAUDTIM NAUDTIM1 NAUDTIM2 NAUDTIM3 NAUDTIM4 NAUDTIM5	(serial audio timing)
:AUDio?	:TIMing?		(returns audio timing string) (returns the signals and amplitudes for the 4 channels of audio)
:BARS	:STANdard	50HZ 60HZ	
	:STANdard?		(returns video standard)
	:SIGNal	SMPTE BARS75 BARS100 BARSBLK	
	:SIGNal?		(returns test signal name)
	:FIEld	<numeric_value>	(-2 to 2 for 2 fields of advance to 2 fields of delay)
	:FIEld?		(returns field timing offset)
	:VERTical	<numeric_value>	(-8 to 8 for 8 lines of advance to 8 lines of delay)
	:VERTical?		(returns lines of timing offset)
	:HCOarse	<numeric_value>	(in integer clock-cycles, for -32 to +32 μ sec offset)
:BARS?	:HCOarse?		(returns horizontal timing offset in μ sec) (returns current test signal, standard, timing offset, and audio OFF)
:BLK1	:STANdard	NTSC PAL	
	:STANdard?		(returns video standard)
	:SIGNal	NBK NNS PBK PBB	(in NTSC, setup off or on; in PAL, F1L7 on or off)
	:SIGNal?		(returns signal name)
	:FIEld	<numeric_value>	(-2 to 2 for 2 fields of advance to 2 fields of delay)
	:FIEld?		(returns fields of timing offset)
	:VERTical	<numeric_value>	(-8 to 8 for 8 lines of advance to 8 lines of delay)
	:VERTical?		(returns lines of timing offset)
	:HCOarse	<numeric_value>	(in integer clock-cycles, for -32 to +32 μ sec offset)
	:HCOarse?		(returns coarse horizontal timing offset in μ sec)
	:HFINE	<numeric_value>	(0 to 255 for 0 to 90 degrees of clock phase)
:BLK1?	:HFINE?		(returns fine horizontal timing offset in μ sec) (returns current black signal, standard, and timing offset)
:BLK2	:STANdard	NTSC PAL	
	:STANdard?		(returns video standard)
	:SIGNal	NBK NNS PBK PBB	(in NTSC, setup off or on; in PAL, F1L7 on or off)
	:SIGNal?		(returns signal name)
	:FIEld	<numeric_value>	(-2 to 2 for 2 fields of advance to 2 fields of delay)
	:FIEld?		(returns fields of timing offset)
	:VERTical	<numeric_value>	(-8 to 8 for 8 lines of advance to 8 lines of delay)
	:VERTical?		(returns lines of timing offset)
	:HCOarse	<numeric_value>	(in integer clock-cycles, for -32 to +32 μ sec offset)
	:HCOarse?		(returns coarse horizontal timing offset in μ sec)
	:HFINE	<numeric_value>	(0 to 255 for 0 to 90 degrees of clock phase)
:BLK2?	:HFINE?		(returns fine horizontal timing offset in μ sec) (returns current black signal, standard, and timing offset)

:BLK3	:STANdard	NTSC PAL	
	:STANdard?		(returns video standard)
	:SIGNal	NBK NNS PBK PBB	(in NTSC, setup off or on; in PAL, F1L7 on or off)
	:SIGNal?		(returns signal name)
	:FIELd	<numeric_value>	(-2 to 2 for 2 fields of advance to 2 fields of delay)
	:FIELd?		(returns fields of timing offset)
	:VERTical	<numeric_value>	(-8 to 8 for 8 lines of advance to 8 lines of delay)
	:VERTical?		(returns lines of timing offset)
	:HCOarse	<numeric_value>	(in integer clock-cycles, for -32 to +32 μ sec offset)
	:HCOarse?		(returns coarse horizontal timing offset in μ sec)
:BLK3?			(returns current black signal, standard, and timing offset)
:BLK4	:STANdard	NTSC PAL	
	:STANdard?		(returns video standard)
	:SIGNal	NBK NNS PBK PBB	(in NTSC, setup off or on; in PAL, F1L7 on or off)
	:SIGNal?		(returns signal name)
	:FIELd	<numeric_value>	(-2 to 2 for 2 fields of advance to 2 fields of delay)
	:FIELd?		(returns fields of timing offset)
	:VERTical	<numeric_value>	(-8 to 8 for 8 lines of advance to 8 lines of delay)
	:VERTical?		(returns lines of timing offset)
	:HCOarse	<numeric_value>	(in integer clock-cycles, for -32 to +32 μ sec offset)
	:HCOarse?		(returns coarse horizontal timing offset in μ sec)
:BLK4?			(returns current black signal, standard, and timing offset)
:BLK5	:STANdard	NTSC PAL	
	:STANdard?		(returns video standard)
	:SIGNal	NBK NNS PBK PBB	(in NTSC, setup off or on; in PAL, F1L7 on or off)
	:SIGNal?		(returns signal name)
	:FIELd	<numeric_value>	(-2 to 2 for 2 fields of advance to 2 fields of delay)
	:FIELd?		(returns fields of timing offset)
	:VERTical	<numeric_value>	(-8 to 8 for 8 lines of advance to 8 lines of delay)
	:VERTical?		(returns lines of timing offset)
	:HCOarse	<numeric_value>	(in integer clock-cycles, for -32 to +32 μ sec offset)
	:HCOarse?		(returns coarse horizontal timing offset in μ sec)
:BLK5?			(returns current black signal, standard, and timing offset)
:BLK6	:STANdard	NTSC PAL	
	:STANdard?		(returns video standard)
	:SIGNal	NBK NNS PBK PBB	(in NTSC, setup off or on; in PAL, F1L7 on or off)
	:SIGNal?		(returns signal name)
	:FIELd	<numeric_value>	(-2 to 2 for 2 fields of advance to 2 fields of delay)
	:FIELd?		(returns fields of timing offset)
	:VERTical	<numeric_value>	(-8 to 8 for 8 lines of advance to 8 lines of delay)
	:VERTical?		(returns lines of timing offset)

	:HCOarse	<numeric_value>	(in integer clock-cycles, for –32 to +32 μsec offset)
:BLK6?	:HCOarse?		(returns coarse horizontal timing offset in μsec) (returns current black signal, standard, and timing offset)
:EDHinsertion		ENA DIS	(enable or disable EDH generation and insertion on all serial digital outputs)
:EDHinsertion?			(returns edh insertion value)
:TEST	:STANdard	50HZ 60HZ	
	:STANdard?		(returns video standard)
	:SIGNal	BARS75 BARS100 PLUGE CONV BOWTIE APMARK MBURST PULSEBAR RAMP SDI TESTBLK	
	:SIGNal?		(returns test signal name)
	:FIEld	<numeric_value>	(–2 to 2 for 2 fields of advance to 2 fields of delay)
	:FIEld?		(returns field timing offset)
	:VERTical	<numeric_value>	(–8 to 8 for 8 lines of advance to 8 lines of delay)
	:VERTical?		(returns lines of timing offset)
	:HCOarse	<numeric_value>	(in integer clock-cycles, for –32 to +32 μsec offset)
	:HCOarse?		(returns horizontal timing offset in μsec)
:STATus	:TEST?		(returns current test signal, standard, and timing)
	:GENLock?		(returns error code from genlock PLD)
	:HELP		(prints out the legal options at the :STAT level of the command menu)
	:HELP?		(prints out the legal options at the :STAT level of the command menu)
	:OPERation	:HELP	(prints out the legal options at the :STAT:OPER level of the command menu)
	:OPERation	:HELP?	(prints out the legal options at the :STAT:OPER level of the command menu)
	:QUEStionable	:HELP	(prints out the legal options at the :STAT:QUES level of the command menu)
	:QUEStionable	:HELP?	(prints out the legal options at the :STAT:QUES level of the command menu)
:SYSTem	:HELP		(prints out the legal options at the :SYST level of the command menu)
	:HELP?		(prints out the legal options at the :SYST level of the command menu)
	:INVenTory?		(returns inventory of installed options)
	:LABel	"instrument_name"	(up to 16 character ID)
	:LABel?		(returns instrument name string)
	:PRESet	<numeric_value>	(1,2,3,4)
	:COPY	<numeric_value, numeric_value>	(source preset, destination preset)
	:INITialize	<presetnumber, standard>	(preset to be initialized, PAL or NTSC)
	:LABel	"presetlabel"	(up to 16 character ID)
	:LABel?		(returns current preset number and label)
	:SElect	<numeric_value>	(select preset 1, 2, 3, or 4)
	:SElect?		(returns current preset number)
	:PRESet?		(returns current preset number and label)
	:SVERsion?		(returns SPG–422 software version number string)

These commands and queries are present in the grammar only to support future development:

*CLS		(clear status command)
*ESE		(standard event status enable command)
*ESE?		(standard event status enable query)
*ESR?		(standard event status register query)
*OPC		(operation complete command)
*OPC?		(operation complete query)
*SRE		(service request enable command)
*SRE?		(service request enable query)
*STB?		(read status byte query)
*TST?		(self-test query)
*WAIT		(wait-to-continue command)
:STATus		
	[:EVENT]	
	[:EVENT]?	
	:OPERation	
		[:EVENT]?
		:CONDition?
		:ENABle
		:ENABle?
	:QUEStionable	
		[:EVENT]?
		:CONDition?
		:ENABle
		:ENABle?
	:PRESet	
:SYSTem		
	:ERRor?	(returns specific error #)
	:VERSion?	(returns SCPI version)

General Command Information

The following are general guidelines for using the Parser:

1. All commands begin with either a colon (:) or an asterisk (*).
2. The Parser has a tree structure. In order to access commands lower on the tree or on a different branch, enter the entire command string.
3. There should not be any spaces between levels of the command string (like a DOS directory).
4. The Parser is case-insensitive (it does NOT care about capitalization). The user can either enter all capitals, all lowercase, or a mixture. (The examples use all capitals only for clarity.)
5. Either the entire command word given in the tree or the abbreviation (the capitalized letters in the tree) can be used.
6. There should be a space between the command string and option. The exception is a query, which ends with a question mark (?).
7. Most commands have a query form. The optional question mark (?) can be used after almost any command string to find out the present state of the SPG 422. There is NOT a space between the command string and the question mark.
8. Most commands have a help function. Typing “help” after a command string will list the commands available at that level. There is a space between the command string and the word “help”.
9. Enter more than one command on a line by using a semicolon (;). There is NOT a space between the command string and the semicolon. This is especially useful for echoing back any changes made.

If the semicolon is separating commands from the same branch of the Parser Tree, it is not necessary to re-enter the entire command string after the semicolon.

If the two commands are from different branches of the tree, there is no shortcut. Enter the entire string.

Explanation of the Parser Commands

This overview lists the Parser commands in alphabetical order. Only the abbreviations are shown here, but you can use the entire word if you prefer. The possible user choices or options are separated by a vertical bar (|).

*CLS

clear status command — for future compatibility

*ESE

standard event status enable command — for future compatibility

*ESE?

standard event status enable query — for future compatibility

*ESR?

standard event status register query — for future compatibility

*IDN?

This command returns the instruments SCPI ID.

*OPC

operation complete command — for future compatibility

*OPC?

operation complete query — for future compatibility

*RST

This command initializes the NVRAM. Note that this command overwrites anything saved in the NVRAM. It resets it to the factory defaults. This command does not return a command prompt. Press ENTER after initialization is complete.

*SRE

service request enable command — for future compatibility

*SRE?

service request enable query — for future compatibility

*STB?

read status byte query — for future compatibility

*TST?

self-test query — for future compatibility

*WAIt

wait-to-continue — for future compatibility

DIAGNOSTIC Commands

Most of the DIAGNOSTIC commands from the front panel are also available from the Parser. They are standard system level commands found under SYST commands. Find the RS-232 test under the ECHO commands.

:DIAGnostic

:DIAGnostic:LCDisplay

Runs the LCD display diagnostics and runs message.

:DIAGnostic:FPLed <value, value, value>

Writes configuration bytes to front-panel LEDs. FOR FUTURE USE.

:DIAGnostic:FPSwitch <loop>

Runs a front panel key exercise if the parameter <loop> is sent. First, all front panel LED's are turned on, to ensure the LEDs operate. After that, pressing any front panel button will turn on the LED for that button, to check the buttons operation. Pressing EXIT will leave this test.

If the parameter <loop> is absent, the routine reads the front panel keyboard and returns scan code and front panel lockout jumper, if any key is selected. If no key is selected, it will return a value of 255.

:DIAGnostic:GENLock

Runs the genlock diagnostics and returns a message. This command does not return a command prompt. Press ENTER after test is complete.

:DIAGnostic:MEMory

NOTE. *this command overwrites anything saved in the NVRAM. The NVRAM is reset to factory defaults.*

Runs a combination of the EPROM test and the RAM test. This command initializes the NVRAM. The EPROM test allows you to run the EPROM checksum test to verify that the EPROM contents are intact. The RAM test allows the user to run the RAM test to verify that the processor RAM and the RAMs in the audio and video generators are functional. The response will be any two of several possible messages:

EPROM TEST PASSED
EPROM TEST FAILED
TEST PASSED
AUDIO RAM FAILED
BARS RAM FAILED
EMBEDDED RAM FAILED
TEST RAM FAILED

This command does not return a command prompt. Press ENTER after tests are complete.

:DIAGnostic:PREMote

Reads the parallel Remote port and returns value read.

:DIAGnostic:SCLock ENA | DIS

Enables/disables GVG serializer to output only serial clock.

:DIAGnostic:VCO <numeric_value>

Sets VCO correction source to contrast DAC and writes specified value to contrast DAC.

DISPLAY Commands

The DISPLAY commands deal with the front-panel menu display.

:DISPlay

:DISPlay:BACKlight ENA | DIS

Enables/disables the Menu Display backlight.

:DISPlay:BACKlight?

Returns the current status of the backlight.

:DISPlay:CONTRast <numeric_value>

Controls the intensity of the front-panel menu display. The value should be an integer number between 1 and 255. One has the least amount of contrast, while 255 has the maximum amount of contrast.

:DISPlay:CONTRast?

Returns the current contrast value.

INPUT Commands

The INPUT commands deal with the genlock input signal (the only signal input to the SPG 422.)

:INPut

:INPut:CONFigure TERM1 | TERM2 | LOOP12

Determines the configuration of the genlock inputs on the rear panel. The options are terminate input 1, terminate input 2, or loopthrough.

:INPut:CONFigure?

Returns the current configuration of the genlock input. It returns either TERM1, TERM2, or LOOP12.

:INPut:FIELD <numeric_value>

Determines the genlock field advance or delay. This command affects the timing of all output signals. The options are +2, +1, 0, -1, or -2 (2 fields advance to 2 fields delay).

:INPut:FIELD?

Returns the current field level offset as a string, where the value is absolute and advance or delay is stated in the following text. For instance, setting to -2 will return "2 Fields of Advance."

:INPut:HCOarse <numeric_value>

Provides the coarse horizontal timing adjustment for the genlock input signal. It moves the genlock signal in clock-cycle increments for a total of 32 μ sec of offset.

:INPut:HCOarse?

Returns the current amount of genlock advance or delay from the coarse horizontal timing. The units are in microseconds.

:INPut:HFINE <numeric_value>

Provides fine horizontal timing offset in sub-clock-cycle increments. The numeric values range from 0 to 1023 and correspond to 0 to 1023/1024^{ths} delay of clock cycles.

:INPut:HFINE?

Returns the current fine horizontal timing of the genlock input signal. Each unit represents 1/1024th of a clock cycle.

:INPut:STANDARD INT | NBL | PBL | NSL | PSL |
 PCW | NCW | OCW | FCW | TCW

Sets the input standard expected from the genlock input. The choices are INT (internal), NBL (NTSC Burst Lock), PBL (PAL Burst Lock), NSL (525/59.94 Sync Lock), PSL (625/50 Sync Lock), PCW (4.43 MHz PAL carrier wave), NCW (3.58 MHz NTSC carrier wave) OCW (1.00 MHz carrier wave), FCW (5.00 MHz carrier wave), or TCW (10.00 MHz carrier wave). The SPG 422 cannot determine the standard of the genlock input. It must be set.

:INPut:STANDARD?

Returns the current genlock standard.

:INPut:VERTical <numeric_value>

Sets the vertical (line) timing offset of the genlock input signal. The options are from 8 lines advance to 8 lines delay.

:INPut:VERTical?

Returns the current vertical offset of the genlock signal.

:INPut?

This query returns the current status of the instrument. Basically it returns the same information given at the top of the Main menu.

OUTPUT Commands

The OUTPUT commands control the many outputs of the SPG 422. These include serial audio, serial digital video, and analog black outputs.

:OUTPut

:OUTPut:AUDio

:OUTPut:AUDio:AEMPhasis NONE | CD | CCITT

Turns on or off the pre-emphasis bits in the serial audio signal. The signal itself does not have pre-emphasis, but you can set the bits in order to check other equipment.

:OUTPut:AUDio:AEMPhasis?

Returns the current pre-emphasis bits settings.

:OUTPut:AUDio:AWIDth 20BIT | 24BIT

Determines whether the audio signal is 20- or 24-bits. There is also a query version of this command that returns the current value. This command affects only the serial and not the embedded audio signals.

:OUTPut:AUDio:AWIDth?

Returns the current audio width.

:OUTPut:AUDio:EAGRoup GROUP1 | GROUP2 | GROUP3 |
GROUP4

Selects the embedded audio group (1-4). Note that this selection affects all serial digital outputs.

:OUTPut:AUDio:EAGRoup?

Returns the current embedded audio group.

:OUTPut:AUDio:EAUDio ENA | DIS

Allows the user to enable or disable the embedded audio signal on all the serial digital video outputs.

:OUTPut:AUDio:EAUDio?

Returns the current state of the embedded audio.

:OUTPut:AUDio:SIGNal <channel, frequency, amplitude>

Controls three Menu commands: channel selection, frequency, and audio level. The channels are 1, 2, 3, 4, or ALL. The frequency choices are 800HZ, 1000HZ, or SILENCE. The audio level can

range from -20 dBFS to -10 dBFS in 2 dBFS intervals. (Enter the level as -10DBFS, -12DBFS, -14DBFS, -16DBFS, -18DBFS, or -20DBFS.)

:OUTPut:AUDio:SIGNal?

Returns the channel, frequency, and amplitude of the audio signal.

```
:OUTPut:AUDio:TIMing PAUDTIM | NAUDTIM1 | NAUDTIM2 |
                    NAUDTIM3 | NAUDTIM4 | NAUDTIM5
```

:OUTPut:AUDio:TIMing?

:OUTPut:AUDio?

Returns the signals and amplitudes for all four audio channels.

:OUTPut:BARs

```
:OUTPut:BARs:FIELD <numeric_value>
```

Sets the field timing offset of the Serial Bars signal relative to the genlock signal. This command can range from 2 fields advance to 2 fields delay. Enter the numeric value as 2, 1, 0, -2, or -1.

:OUTPut:BARs:FIELD?

Returns the current field timing of the bars signal relative to the genlock signal as a string, where the value is absolute and advance or delay is stated in the following text. For instance, setting to -2 will return "2 Fields of Advance."

```
:OUTPut:BARs:HCOarse <numeric_value>
```

Sets the coarse horizontal timing relative to the genlock signal. The timing resolution is clock-cycles. The range is ± 32 μ sec. Positive numbers set delay and negative numbers set advance.

NOTE. The numeric value for this command is expressed in clock-cycles, **not** microseconds. There is a conversion factor dependent upon the video standard in use.

:OUTPut:BARs:HCOarse?

Returns the current coarse timing settings in microseconds.

```
:OUTPut:BARs:SIGNal SMPTE | BARS75 | BARS100 |
                    BARSBLK
```

Selects which signal to output from the bars BNC connector on the rear panel. The choices are 525/59.94 SMPTE color bars (SMPTE),

75% color bars (BARS75), 100% color bars (BARS100), or black (BARSBLK). SMPTE is valid only in 60 Hz standard.

:OUTPut: BARS: SIGNAL?

Returns the current Bars output signal.

:OUTPut: BARS: STANDARD 50HZ | 60HZ

Selects between the 525/59.94 and the 625/50 video standards for the Serial Bars signal.

:OUTPut: BARS: STANDARD?

Returns the current video standard.

:OUTPut: BARS: VERTICAL <numeric_value>

Selects the vertical timing offset for the Serial Bars signal. The range is from +8 to -8 lines. The command form is -8, -7, -6, -5, -4, -3, -2, -1, 0, 1, 2, 3, 4, 5, 6, 7, or 8.

:OUTPut: BARS: VERTICAL?

Returns the current vertical offset for the Serial Bars signal in lines as a string, where the value is absolute and advance or delay is stated in the following text. For instance, setting to -6 will return "6 Lines of Advance".

:OUTPut: BARS?

Returns the current bars signal, standard, timing offset, and black signal audio mode.

:OUTPut: BLK1

:OUTPut: BLK2

:OUTPut: BLK3

:OUTPut: BLK4

:OUTPut: BLK5

:OUTPut: BLK6

:OUTPut: BLK1: FIELD <numeric_value>

:OUTPut: BLK2: FIELD <numeric_value>

:OUTPut: BLK3: FIELD <numeric_value>

:OUTPut: BLK4: FIELD <numeric_value>

:OUTPut: BLK5: FIELD <numeric_value>

:OUTPut: BLK6: FIELD <numeric_value>

Selects the amount of field offset (from the reference genlock) for the select black output signal. It can range from 2 fields advance to 2 fields delay. Enter one of the following values: -2, -1, 0, 1, or 2.

```
:OUTPut:BLK1:FIELD?
:OUTPut:BLK2:FIELD?
:OUTPut:BLK3:FIELD?
:OUTPut:BLK4:FIELD?
:OUTPut:BLK5:FIELD?
:OUTPut:BLK6:FIELD?
```

Returns the current amount of field offset for the selected black signal as a string, where the value is absolute and advance or delay is stated in the following text. For instance, setting to -2 will return "2 Fields of Advance".

```
:OUTPut:BLK1:HCOarse <numeric_value>
:OUTPut:BLK2:HCOarse <numeric_value>
:OUTPut:BLK3:HCOarse <numeric_value>
:OUTPut:BLK4:HCOarse <numeric_value>
:OUTPut:BLK5:HCOarse <numeric_value>
:OUTPut:BLK6:HCOarse <numeric_value>
```

Selects the amount of coarse horizontal offset timing for the selected black output signal. The units are in clock-cycles and the range is $\pm 32 \mu\text{sec}$.

```
:OUTPut:BLK1:HCOarse?
:OUTPut:BLK2:HCOarse?
:OUTPut:BLK3:HCOarse?
:OUTPut:BLK4:HCOarse?
:OUTPut:BLK5:HCOarse?
:OUTPut:BLK6:HCOarse?
```

Returns the amount of coarse horizontal timing offset that exists between the selected black and the reference genlock signal. The units are in microseconds.

```
:OUTPut:BLK1:HFINE <numeric_value>
:OUTPut:BLK2:HFINE <numeric_value>
```

Selects the amount of fine horizontal timing offset of the select black output signal. The units are in sub-clock-cycles. This command is only available for the two standard Black outputs. The available range is from 0 to 1023, which represents 0 to $1023/1024^{\text{th}}$ delay clock cycles.

```
:OUTPut:BLK1:HFINE?
:OUTPut:BLK2:HFINE?
```

Returns the amount of horizontal timing offset that is added to the selected black signal. This command is only available for the two standard Black outputs.

```

:OUTPut:BLK1:SIGNal  NBK | NNS | PBK | PBB
:OUTPut:BLK2:SIGNal  NBK | NNS | PBK | PBB
:OUTPut:BLK3:SIGNal  NBK | NNS | PBK | PBB
:OUTPut:BLK4:SIGNal  NBK | NNS | PBK | PBB
:OUTPut:BLK5:SIGNal  NBK | NNS | PBK | PBB
:OUTPut:BLK6:SIGNal  NBK | NNS | PBK | PBB

```

Selects what kind of analog black signal is available from the selected black BNC connector. If the standard is NTSC, then the options are with (NBK) or without setup (NNS). If the standard is PAL, then the options are color black (PBK) or black with FIL7 pulse (PBB). Use the `:OUTP:BLK#:STAN` command to change the video standard.

```

:OUTPut:BLK1:SIGNal?
:OUTPut:BLK2:SIGNal?
:OUTPut:BLK3:SIGNal?
:OUTPut:BLK4:SIGNal?
:OUTPut:BLK5:SIGNal?
:OUTPut:BLK6:SIGNal?

```

Returns the current black output signal.

```

:OUTPut:BLK1:STANdard NTSC | PAL
:OUTPut:BLK2:STANdard NTSC | PAL
:OUTPut:BLK3:STANdard NTSC | PAL
:OUTPut:BLK4:STANdard NTSC | PAL
:OUTPut:BLK5:STANdard NTSC | PAL
:OUTPut:BLK6:STANdard NTSC | PAL

```

Selects the video standard for the selected output black signal. The choices are NTSC or PAL. Each of the black output signals can have different standards.

```

:OUTPut:BLK1:STANdard?
:OUTPut:BLK2:STANdard?
:OUTPut:BLK3:STANdard?
:OUTPut:BLK4:STANdard?
:OUTPut:BLK5:STANdard?
:OUTPut:BLK6:STANdard?

```

Returns the current video standard for the selected black output.

```

:OUTPut:BLK1:VERTical <numeric_value>
:OUTPut:BLK2:VERTical <numeric_value>
:OUTPut:BLK3:VERTical <numeric_value>
:OUTPut:BLK4:VERTical <numeric_value>
:OUTPut:BLK5:VERTical <numeric_value>
:OUTPut:BLK6:VERTical <numeric_value>

```

Selects the vertical timing offset for the selected black output. The vertical interval ranges from 8 lines advance to 8 lines delay relative to the genlock signal. Enter one of the following numbers: -8, -7, -6, -5, -4, -3, -2, -1, 0, 1, 2, 3, 4, 5, 6, 7, or 8.

```
:OUTPut:BLK1:VERTical?
:OUTPut:BLK2:VERTical?
:OUTPut:BLK3:VERTical?
:OUTPut:BLK4:VERTical?
:OUTPut:BLK5:VERTical?
:OUTPut:BLK6:VERTical?
```

Returns the current amount of vertical timing offset on the selected black signal as a string, where the value is absolute and advance or delay is stated in the following text. For instance, setting to -6 will return "6 Lines of Advance."

```
:OUTPut:BLK1?
:OUTPut:BLK2?
:OUTPut:BLK3?
:OUTPut:BLK4?
:OUTPut:BLK5?
:OUTPut:BLK6?
```

Returns the current black signal, standard, and timing offset.

```
:OUTPut:EDHinsertion ENA | DIS
```

Enables or disables Error Detection and Handling insertion (per SMPTE RP165) for all serial digital video outputs.

```
:OUTPut:EDHinsertion?
```

Returns the current Error Detection and Handling insertion status.

```
:OUTPut:TEST
```

```
:OUTPut:TEST:FIELD <numeric_value>
```

Sets the serial signal field timing offset. The range is from 2 fields advance to 2 fields delay. Enter one of the following numbers: -2, -1, 0, 1, or 2. This command is only available when option 2 is installed.

```
:OUTPut:TEST:FIELD?
```

Returns the amount of field offset currently present on the test signal output as a string, where the value is absolute and advance or delay is stated in the following text. For instance, setting to -2 will return "2 Fields of Advance". This command is only available when option 2 is installed.

`:OUTPut:TEST:HCOarse <numeric_value>`

Sets the amount of horizontal delay between the serial signal and the genlock reference. The units are in clock-cycles and the range is $\pm 32 \mu\text{sec}$. This command is only available if option 2 is installed.

`:OUTPut:TEST:HCOarse?`

Returns the current amount of timing offset between the serial signal and the reference genlock. The units are in microseconds. This command is only available if option 2 is installed.

`:OUTPut:TEST:SIGNal` BARS75 | BARS100 | PLUGE | CONV
 | BOWTIE | APMARK | MBURST |
 PULSEBAR | RAMP | SDI | TESTBLK

Selects which serial signal is available from the Serial Signal BNC connectors on the rear panel. The options are as follows:

75% color bars	BARS75
100% color bars	BARS100
full field pluge	PLUGE
convergence	CONV
bowtie	BOWTIE
active picture markers	APMARK
multiburst	MBURST
pulse and bar	PULSEBAR
luminance ramp	RAMP
SDI check field matrix	SDI
black	TESTBLK

This command is only available when option 2 is installed. This command might not access all signals provided by option 2.

`:OUTPut:TEST:SIGNal?`

Returns the current test signal selection. This command is only available if option 2 is installed.

`:OUTPut:TEST:STANdard 50HZ | 60HZ`

Selects the video standard for the serial signal output. It can be either NTSC (60HZ) or PAL (50HZ). This command is only available if option 2 is installed.

`:OUTPut:TEST:STANdard?`

Returns the current video standard for the test signal output. This command is only available if option 2 is installed.

`:OUTPut:TEST:VERTical <numeric_value>`

Sets the vertical timing offset between the serial test signal and the reference genlock. The options are from 8 lines advance to 8 lines delay in 1-line intervals. The options are -8, -7, -6, -5, -4, -3, -2, -1, 0, 1, 2, 3, 4, 5, 6, 7, or 8. This command is only available if option 2 is installed.

`:OUTPut:TEST:VERTical?`

Returns the current amount of offset between the test signal and the reference genlock signal as a string, where the value is absolute and advance or delay is stated in the following text. For instance, setting to -6 will return "6 Lines of Advance.". This command is only available if option 2 is installed.

`:OUTPut:TEST?`

Returns the current test signal, standard, and timing. Available only if option 02 is installed.

STATUS Commands

The STATUS commands determine genlock condition. Some of these commands are only in place for future enhancements.

`:STATus`

For future compatibility

`:STATus[:EVENT]`

For future compatibility

`:STATus:HELP`

`:STATus:HELP?`

Returns the legal options at the :STAT command level.

:STATus:GENLock?

Returns the error code from the genlock PLD. This error code is the sum of one or more errors:

Identifier	Error Code	Front Panel Message	Description
GNLKINT_OK	0X00		Genlock result if all is OK.
COLOR_ACQ_DONE	0X01	GENLOCK ACQUIRED	Color Acquisition Done
SYNC_BURST_ABSENT	0X02	REF SOURCE UNKNOWN	Sync/burst absent flag
SYNC BURST UNLOCKED	0X04	REF LOCK ERROR	Sync/Burst unlocked flag
VCO ERROR	0X08	REF FREQUENCY ERROR	VCO Error
HORIZONTAL_ERROR	0X10	REF LINE ERROR	Horizontal counter error
VERTICAL_ERROR	0X20	REF FIELD ERROR	Vertical counter error
FRAME_ERROR	0X40	REF FRAME ERROR	Frame counter error
HEATER_ERROR	0X80	INT REF TEMP ERROR	Oven temperature error

:STATus:OPERation

For future compatibility

:STATus:OPERation:CONDition?

For future compatibility

:STATus:OPERation:ENABle

For future compatibility

:STATus:OPERation:ENABle?

For future compatibility

:STATus:OPERation:HELP

:STATus:OPERation:HELP?

Returns the legal options at the :STAT:OPER command level.

:STATus:OPERation[:EVENT]?

For future compatibility

:STATus:PRESet

For future compatibility

:STATus:QUESTionable

For future compatibility

:STATus:QUESTionable:CONDition?

For future compatibility

:STATus:QUEStionable:ENABle

For future compatibility

:STATus:QUEStionable:ENABle?

For future compatibility

:STATus:QUEStionable:HELp
:STATus:QUEStionable:HELp?

Returns the legal options at the :STAT:QUES command level.

:STATus:QUEStionable[:EVENT]?

For future compatibility

:STATus[:EVENT]

For future compatibility

:STATus[:EVENT]?

For future compatibility

SYSTEM Commands

The following commands are system level and diagnostic commands, not routinely used by an operator.

:SYSTem

:SYSTem:ERRor?

For future compatibility

:SYSTem:HELp
:SYSTem:HELp?

Returns the legal options at the :STAT command level.

:SYSTem:INVenTory?

Returns what options this instrument has installed. The available responses are standard instrument, Option 1 installed, Option 2 installed, or Options 1 and 2 installed.

:SYSTem:LABel <instrument_name>

Sets the ID for the SPG 422. The desired ID (up to 16 characters) is after the command.

:SYSTEM:LABEL?

Returns the current ID of the SPG 422.

:SYSTEM:PRESet¹ <numeric_value>

Selects a preset to load. The options are 1, 2, 3, or 4.

:SYSTEM:PRESet:COpy¹ <source, destination>



CAUTION. *This command completely overwrites the destination preset.*

Copies the preset information from one preset (source: 1, 2, 3, or 4) to another (destination: 1, 2, 3, or 4).

:SYSTEM:PRESet:INITialize¹ <preset_number, standard>



CAUTION. *This command erases all custom presets.*

Re-initializes the selected preset back to the factory settings for the given video standard. The preset numbers are 1, 2, 3, or 4. The standard is either NTSC or PAL.

:SYSTEM:PRESet:LABel¹ <"preset_label">

Creates an ID for the current preset. This command allows the user to give meaningful names to the presets. There is a limit of 16 characters.

:SYSTEM:PRESet:LABel?¹

Returns the ID of the current preset.

:SYSTEM:PRESet:SElect¹ <numeric_label>

Select from the available presets. The choices are 1, 2, 3, or 4.

:SYSTEM:PRESet:SElect?¹

Returns the current preset number.

:SYSTEM:PRESet?¹

Returns the current preset number and label.

:SYSTEM:SVERSion?

Returns the software version of the SPG 422. This is very useful for checking upgrades, etc.

:SYSTem:VERSion?

For future compatibility

¹ The SYSTem:PRESet commands are disabled at the time of this printing.

Using the Ground-Closure Remote

The rear-panel connector can also be a simple ground-closure remote. (Set internal jumpers to access this configuration.) In this setup, the 9-pin female D-connector has one pin tied to ground. All signals are active low.

The connector has the following pinout (looking at the rear of the instrument):

Pin	Signal function
1	Home Signal
2	Increment Bars signal
3	Increment Serial signal
4	Genlock Auto/Internal
5	Preset Select 0 (LSB)
6	Preset Select 1 (MSB)
7	Unused
8	Preset Select Enable
9	Ground

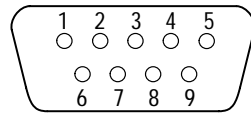

The Increment Bars signal and Increment Serial signal lines are intended to be used with momentary-contact switches. These signals are therefore at a high priority level, with delays and retriggering implemented in software.

The remaining lines are intended to be used with static-contact switches. These signals are only acted upon when they change state. While switching, they are at high priority, but are ignored after being serviced. However, because the remote control must remain in control for these signals (the remote status cannot be changed from the instrument), priority is maintained by the remote for all functions directly controlled by the remote. (For example, if the remote specifies internal genlock operation, the front panel is not allowed to override it.) All lines are pulled high internally; Hi (1) = Open, Low (0) = GND.

Home Signal

The Home signal does nothing by itself. If the Increment Bars signal or Increment Test signal lines are low while the Home Signal Line is low, then the signal pointer goes to the top of the signal list. This sets the signal selector to a known state.

Increment Bars Signal

Scrolls through the list of available Bars signals.

Increment Serial Signal

Scrolls through the lists of available Serial signals. (Only available if option 2 is installed.)

Genlock Auto/Internal

Toggles between forcing the use of the internal clock and using an external reference whenever it is available.

Preset Select 1/0 Does nothing if the Preset Select Enable is high. If the Preset Select Enable is low, then it selects from Presets 0 through 3. Set the presets via the front-panel menu commands. (11=preset 0, 10=preset 1, 01=preset 2, and 00=preset 3) Preset 0 is the default.

Preset Select Enable Enables recalling a Preset. Preset Select 0 and Preset Select 1 lines define which preset is being recalled.



Appendices

Appendix A: Specifications

The items listed in the following tables describe the performance of the SPG 422 Component Digital Sync Generator. Performance requirements are generally quantitative and can be tested by the Performance Verification procedure contained in the *Service* manual.

The Reference Information column contains valuable data pertaining to the operation and output capabilities of this instrument. The Performance Verification procedure tests only a few of these items.

The SPG 422 Component Digital Sync Generator is intended to operate from an AC power source that will not apply more than 250 V_{RMS} between the supply conductors or either supply conductor and ground. A protective ground connection by way of the grounding conductor is essential for safe operation.

Environmental specifications and a list of appropriate safety and electromagnetic interference (EMI) standards begin on page A-24.

Performance Conditions

The requirements listed in the electrical specification portion of these specifications apply over an ambient temperature range of 0° C to +40° C. The rated accuracies are valid when the instrument is calibrated at an ambient temperature range of +20° C to +30° C, after a warm-up time of 20 minutes. Test equipment used to verify Performance Requirements must be calibrated and working within the limits specified under the Equipment Required list.

Characteristics Tables

Table A-1: Encoding Parameters for Serial Digital Video Outputs

Characteristics	Performance Requirements	Reference Information	
Standards Conformance		ITU-R BT.601 and ITU-R BT.656, SMPTE 125M, EBU Tech. 3267-E	
Coded Signals		Luminance (Y), and color difference (C_r and C_b)	
Number of Samples per Video Line		525/59.94	625/50
Luminance (Y)		858	864
Color Difference (C_r and C_b)		429	432
Sampling Structure		Orthogonal: line, field, and frame repetitive. C_r and C_b samples are co-sited with odd Y samples in each line.	
Sampling Frequency		13.5 MHz nominal	
Luminance (Y)		6.75 MHz nominal	
Color Difference (C_r and C_b)			
Signal Coding		Uniformly quantized PCM, 10 bits per sample, for each luminance and color-difference signal.	
Number of Samples per Digital Active Line		525/59.94	625/50
Luminance (Y)		720	720
Color Difference (C_r and C_b)		360	360
Correspondence Between Video Signal Levels and Quantization Levels		877 quantization levels, with black level corresponding to level 64 and the peak white level corresponding to level 940.	
Luminance (Y)			
Color Difference (C_r and C_b)		897 quantization levels symmetrically distributed around level 512, which corresponds to zero signal.	

Table A-2: Timing Relationships for Serial Digital Video Outputs

Characteristics	Reference Information						
Standards Conformance	ITU-R BT.601 and ITU-R BT.656, SMPTE 125M, EBU Tech. 3267-E						
Line Timing							
525/59.94	See Figure A-1.						
625/50	See Figure A-2.						
Field Timing							
625/50	See Figure A-3.						
525/59.94	See Figure A-4.						
Timing Reference Signal	Bit	1st Word	2nd Word	3rd Word	4th Word		
End of Active Video/Start of Active Video (EAV/SAV)	9	1	0	0	1		
	8	1	0	0	F		
	7	1	0	0	V		
	6	1	0	0	H		
	5	1	0	0	P3		
	4	1	0	0	P2		
	3	1	0	0	P1		
	2	1	0	0	P0		
	1	1	0	0	0		
	0	1	0	0	0		
	where:						
	F = 1 during field 2,						
	V = 1 during vertical blanking,						
	H = 1 during horizontal blanking,						
	The protection bits are:						
	F	V	H	P3	P2	P1	P0
	0	0	0	0	0	0	0
	0	0	1	1	1	0	1
	0	1	0	1	0	1	1
	0	1	1	0	1	1	0
	1	0	0	0	1	1	1
	1	0	1	1	0	1	0
	1	1	0	1	1	0	0
	1	1	1	0	0	0	1

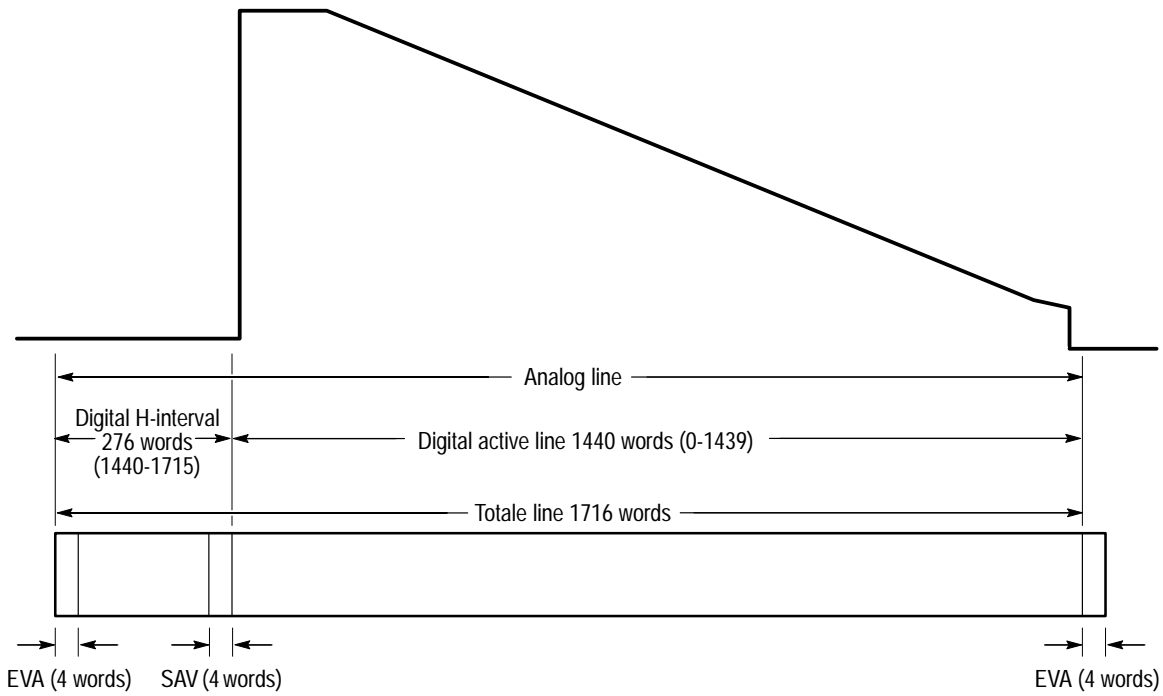
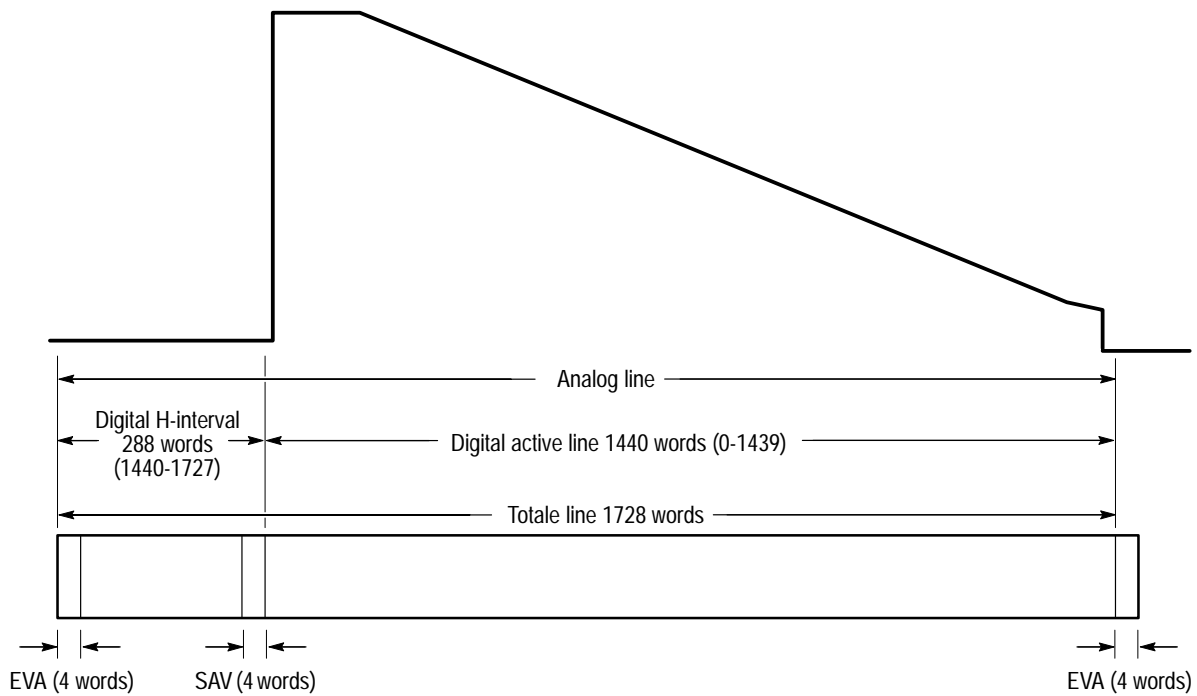

Figure A-1: Timing Relationship between the Digital Video Data and the Analog line Synchronization (Reference for Line Scanning) in the 525/60 system



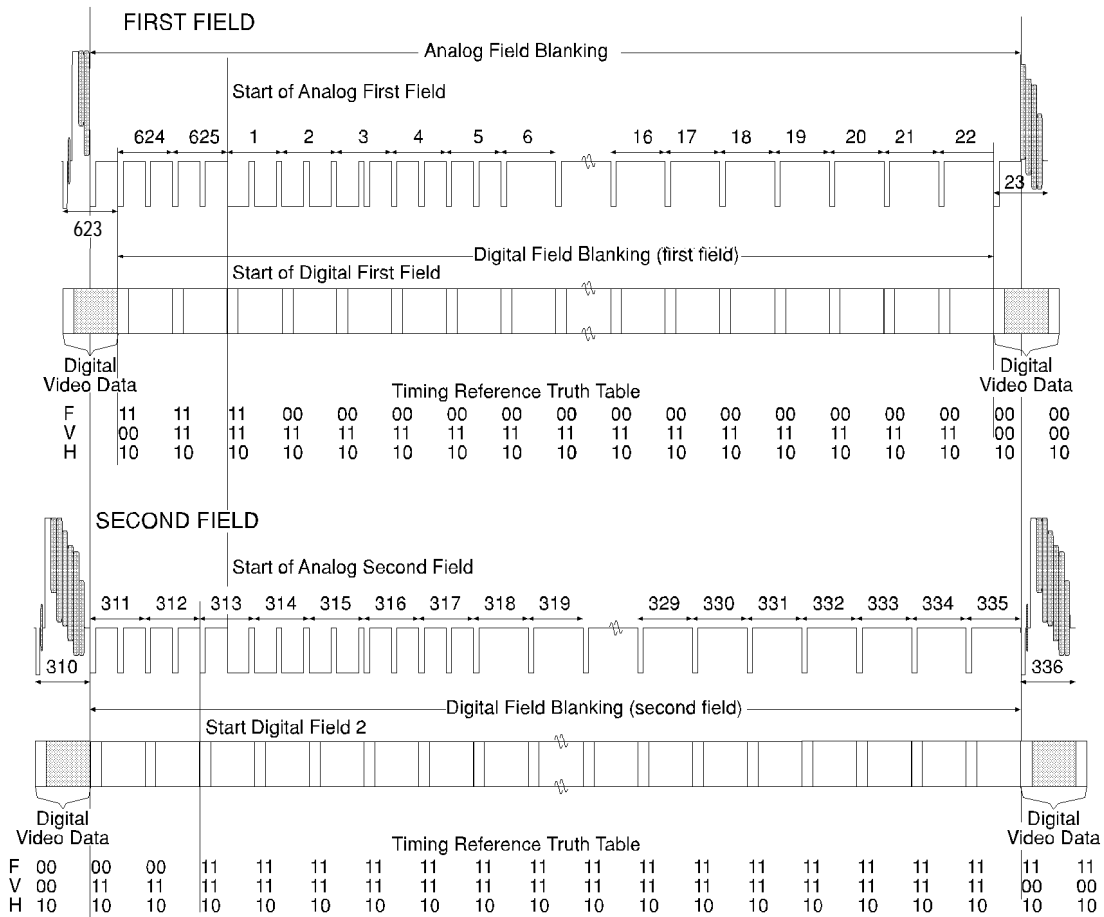

Figure A-3: Relationship between the Digital and Analog Fields, showing also the Position of the Digital Field-Blanking Interval in the 625 System

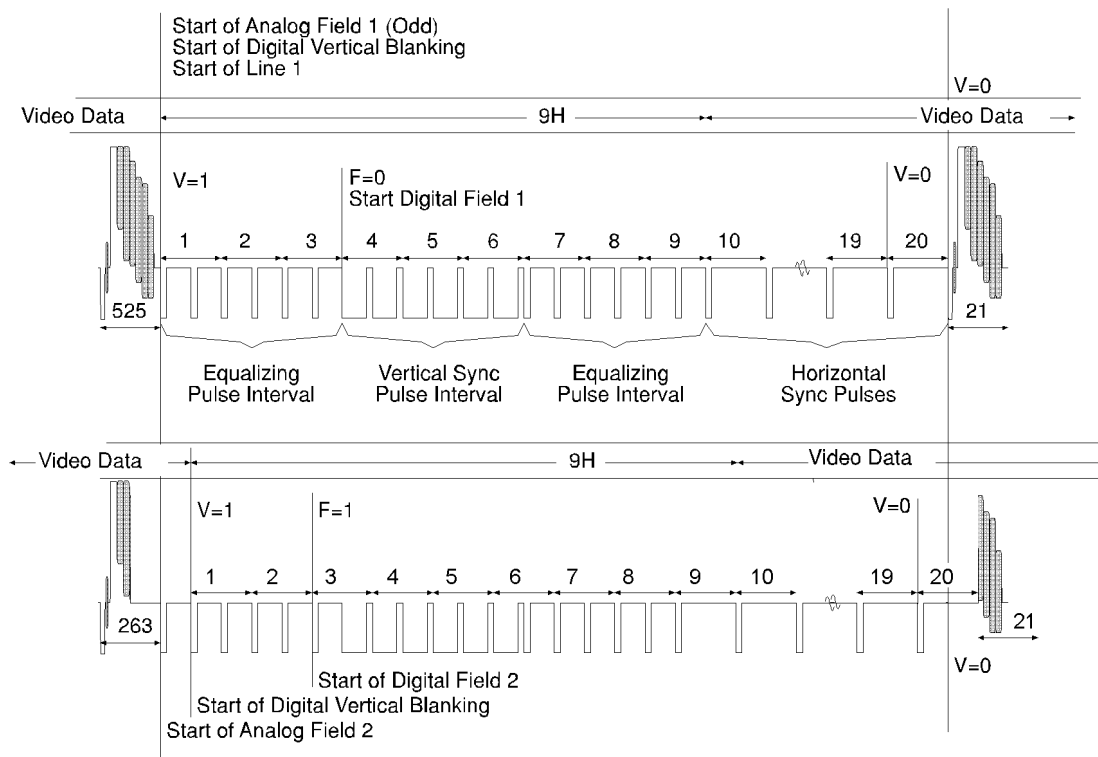

Figure A-4: Relationship of Video Data/Vertical Sync in the 525 System

Table A-3: Output Characteristics for Serial Digital Video Signals

Characteristics	Performance Requirements	Reference Information
Standards Conformance		SMPTE 259M, EBU Tech 3267-E ITU-R BT.601 and ITU-R BT.656
Connector		BNC
Digital Format		Scrambled NRZI
Serial Bit Rate		270 Mbits/sec
Source Impedance		75Ω
Return Loss		≥15 dB from 5 MHz to 270 MHz
Signal Amplitude	800 mV ± 10%	75Ω load impedance, with no transmission line
DC Offset	0 V ± 0.5 V	
Rise and Fall Times	0.40 to 1.50 nsec	Measured between 20% and 80% amplitude points
Difference Between Rise and Fall Time	0.5 nsec	Measured between 20% and 80% amplitude points
Jitter		Less than ± 0.25 nsec over a period of one video line
Required Receiver Termination		75Ω, with return loss ≥15 dB from 5 MHz to 270 MHz

Table A-4: Signal Characteristics for Analog Black Outputs (in base instrument only)

Characteristics	Performance Requirements	Reference Information
Standards Conformance		SMPTE 170M (NTSC), EBU N14-1988
Blanking Level	$0\text{ V} \pm 100\text{ mV}$	
Blanking Width (NTSC only)		$10.7\ \mu\text{sec} \pm 0.2\ \mu\text{sec}$
Black Level NTSC PAL		0 or 7.5 IRE (user selectable) Blanking Level
Sync Rise Time NTSC PAL		140 nsec 250 nsec
Sync Amplitude NTSC PAL	$-40\text{ IRE} \pm 2\text{ IRE}$ $-300\text{ mV} \pm 15\text{ mV}$	
White Flag Level PAL only		0 or 700 mV (user selectable)
Sync Timing NTSC PAL		See Figures A-5 and A-6. See Figure A-7.
Burst Rise Time NTSC PAL		400 nsec 350 nsec
Burst Amplitude NTSC PAL	$40\text{ IRE}_{p-p} \pm 2\text{ IRE}$ $300\text{ mV}_{p-p} \pm 15\text{ mV}$	
Burst Delay from Sync NTSC PAL		19 cycles of subcarrier 25 cycles of subcarrier
Burst Duration NTSC PAL		9 cycles of subcarrier 10 cycles of subcarrier
Burst Frequency NTSC PAL		$3.579545\text{ MHz} \pm 1\text{ Hz}$ $4.43361875\text{ MHz} \pm 1\text{ Hz}$
SC/H Phase Accuracy	$0^\circ \pm 5^\circ$	
Field Timing Offset Range	$\pm 2\text{ fields}$	Relative to the genlock input
Field Timing Offset Resolution		Video field increments
Vertical Timing Offset Range	$\pm 8\text{ lines}$	Relative to the genlock input

Table A-4: Signal Characteristics for Analog Black Outputs (in base instrument only) (Cont.)

Characteristics	Performance Requirements	Reference Information
Vertical Timing Offset Resolution		Video line increments
Horizontal Timing Offset Range	$\pm 1/2$ video line	Relative to the genlock input
Horizontal Timing Offset Resolution		$< 0.1^\circ$ of subcarrier
Horizontal Timing Offset Range	$\pm 1/2$ video line	Relative to the genlock input
Return Loss	≥ 30 dB	0 – 5 MHz

Table A-5: Signal Characteristics for Analog Black Outputs (in Option 1 only)

Characteristics	Performance Requirements	Reference Information
Standards Conformance		SMPTE 170M (NTSC), EBU N14-1988
Blanking Level	$0\text{ V} \pm 100\text{ mV}$	
Blanking Width NTSC only		$10.7\ \mu\text{sec} \pm 0.2\ \mu\text{sec}$
Black Level NTSC PAL		0 or 7.5 IRE (user selectable) Blanking Level
Sync Rise Time NTSC PAL		140 nsec 250 nsec
Sync Amplitude NTSC PAL	$-40\text{ IRE} \pm 2\text{ IRE}$ $-300\text{ mV} \pm 15\text{ mV}$	
White Flag Level PAL only		0 or 700 mV (user selectable)
Sync Timing NTSC PAL		See Figures A-5 and A-6. See Figure A-7.
Burst Rise Time NTSC PAL		400 nsec 350 nsec
Burst Amplitude NTSC PAL	$40\text{ IRE}_{\text{p-p}} \pm 2\text{ IRE}$ $300\text{ mV}_{\text{p-p}} \pm 15\text{ mV}$	
Burst Delay from Sync NTSC PAL		19 cycles of subcarrier 25 cycles of subcarrier
Burst Duration NTSC PAL		9 cycles of subcarrier 10 cycles of subcarrier
Burst Frequency NTSC PAL		$3.579545\text{ MHz} \pm 1\text{ Hz}$ $4.43361875\text{ MHz} \pm 1\text{ Hz}$
SC/H Phase Accuracy	$0^\circ \pm 5^\circ$	
Field Timing Offset Range	$\pm 2\text{ fields}$	Relative to the genlock input
Field Timing Offset Resolution		Video field increments
Vertical Timing Offset Range	$\pm 8\text{ lines}$	Relative to the genlock input

Table A-5: Signal Characteristics for Analog Black Outputs (in Option 1 only) (Cont.)

Characteristics	Performance Requirements	Reference Information
Vertical Timing Offset Resolution		
Horizontal Timing Offset Range	$\pm 1/2$ video line	
Horizontal Timing Offset Resolution		Single 27 MHz clock cycles
Return Loss	≥ 30 dB	0 – 5 MHz

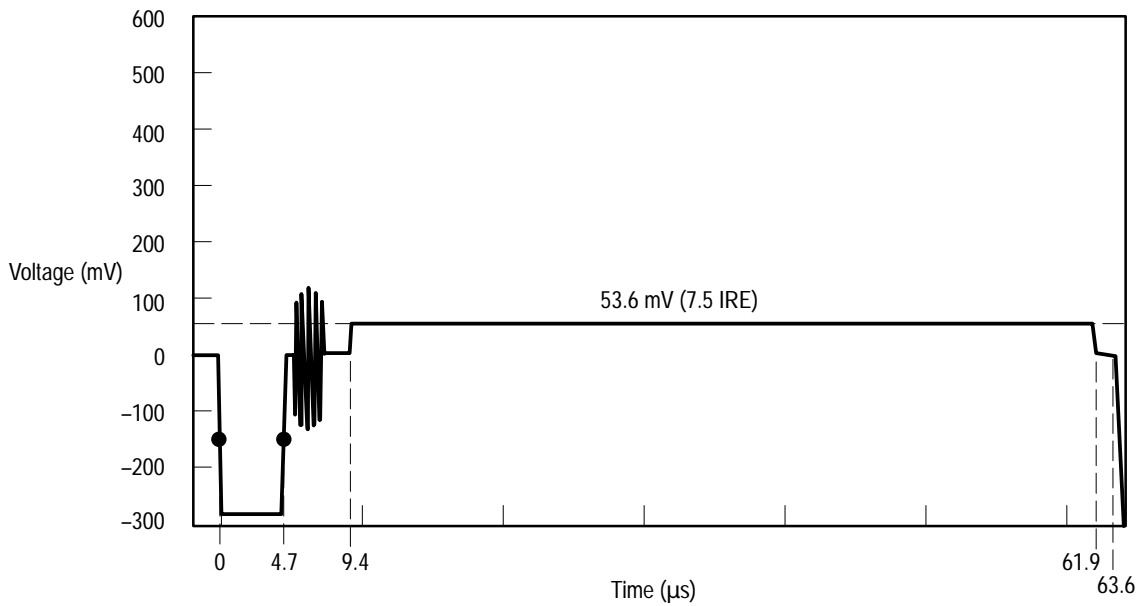

Figure A-5: 60 Hz Black Burst with 7.5 IRE Setup

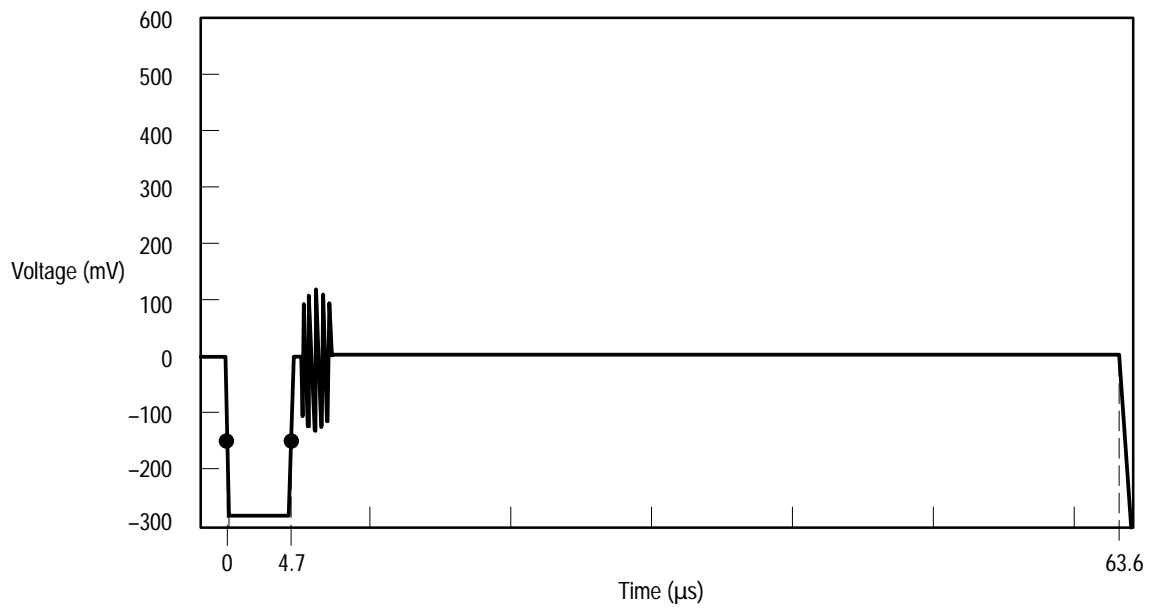

Figure A-6: 60 Hz Black Burst with No Setup

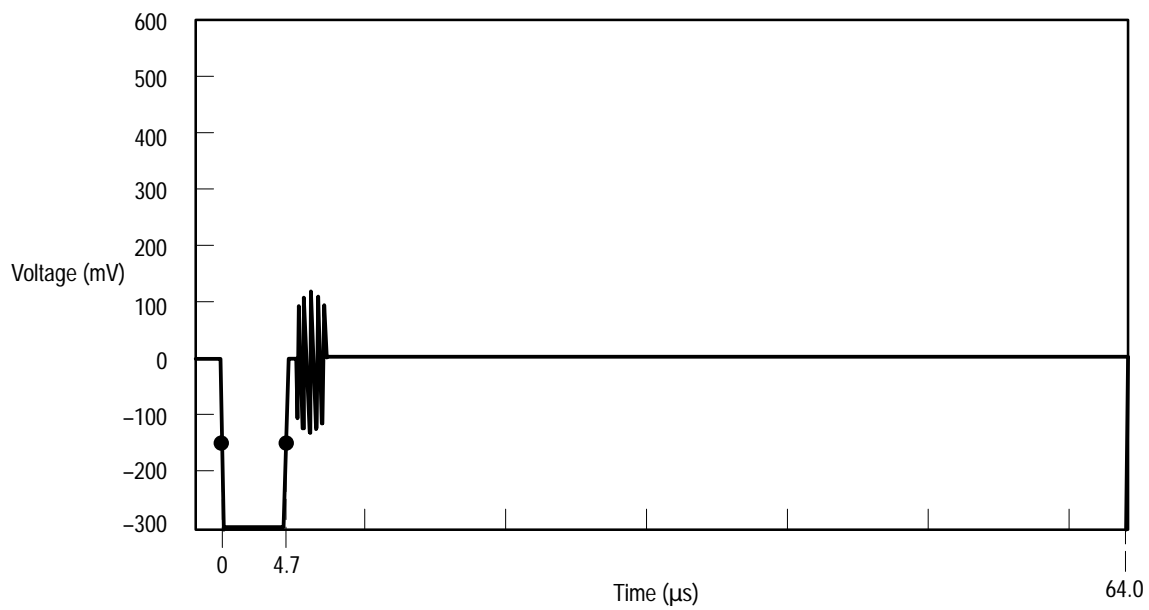

Figure A-7: 50 Hz Black Burst

Table A-6: Signal Characteristics for Serial Bars Output

Characteristics	Performance Requirements	Reference Information
Standards Conformance		SMPTE RP 165, SMPTE 259M
Serial Bars Output Signal	75% Bars	525 and 625 formats available. See Figures A-8, A-9, and A-10.
	100% Full-Field Bars	525 and 625 formats available. See Figures A-11, A-12, and A-13.
	75% Bars over Red	625/50 format only See Figures A-8, A-9, A-10, A-14, A-15, and A-16.
	Field Timing Color Bars Red	Lines 23 – 166 Lines 167 – 310
	100% Bars over Red	625/50 format only See Figures A-11, A-12, A-13, A-17, A-18 and A-19.
	Field Timing Color Bars Red	Lines 23 – 166 Lines 167 – 310
Serial Black	SMPTE Bars	525/59.94 format only See Figures A-20 through A-28.
	Serial Black	525 and 625 formats available.
Error Detection and Handling Insertion		Can be enabled or disabled by user
Field Timing Offset Range	± 1 field	Relative to the genlock input
Field Timing Offset Resolution		Video field increments
Vertical Timing Offset Range	± 8 lines	Relative to the genlock input
Vertical Timing Offset Resolution		Video line increments
Horizontal Timing Offset Range	$\pm 1/2$ video line	Relative to the Genlock input
Horizontal Timing Offset Resolution		Single 27 MHz clock-cycles

Table A-7: Signal Characteristics for Serial Test Signal (Option 2 only)

Characteristics	Performance Requirements	Reference Information
Standards Conformance		SMPTE RP 165, SMPTE 259M
Serial Test Signals	75% Bars	See Figures A-8, A-9, and A-10.
	100% Bars	See Figures A-11, A-12, and A-13.
	Full-field Pluge	See Figures A-49 and A-50.
	Convergence	See Figures A-34 & A-35 (H), and A-36 & A-37 (V)
	Bowtie	See Figures A-43, A-44, and A-45.
	Active Picture Markers	See Figures A-38 through A-42.
	Multiburst	See Figures A-29 and A-30.
	Pulse And Bar	See Figures A-31, A-32, and A-33.
	Ramp	See Figures A-46, A-47, and A-48.
	Serial Digital Interface (SDI matrix)	<p>Matrix consists of Bit Slip and Clock Recovery Test signal and the Equalizer signal per SMPTE RP 178.</p> <p>Bit Slip stresses the recovery ability of the receiver clock regenerator by sending a string of twenty 0s followed by a single 1.</p> <p>The Equalizer Test signal contains a maximum low frequency content. It repeats a string of nineteen 0s followed by two 1s.</p>
	Serial Black	525 and 625 formats available.
	White Bar	See Figures A-41 and A-42.
EDH Insertion		Can be enabled or disabled by user.
Field Timing Offset Range	± 1 field	Relative to the genlock input
Field Timing Offset Resolution		Video field increments
Vertical Timing Offset Range	± 8 lines	Relative to the genlock input
Vertical Timing Offset Resolution		Video line increments

Table A-8: Signal Characteristics for AES/EBU Serial Digital Audio Outputs (XLR connectors)

Characteristics	Performance Requirements	Reference Information
Standards Conformance		ANSI S4.40, SMPTE RP 155-1990
Audio Connectors	2	3-pin XLRs, male contacts
Audio Timing		
Digital Format		Serial, balanced signal pair and a signal ground
Digital Code		Bi-phase mark
Output Level	2-7 V_{p-p}	Measured differentially across 110 Ω .
Required Receiver Termination	110 $\Omega \pm 10\%$	
Encoding Format		Linear PCM, two's complement binary representation.
Audio Sampling Frequency		48.000 kHz, locked to video
Number of Audio Channels	4	2 AES/EBU audio pairs on each audio connector
Quantized Resolution		20 or 24 bits (user selectable)
Audio Tone Frequency	800 Hz or 1 kHz or Silence (audio black)	User selectable, channel-by-channel
Audio Tone Amplitude	-10 to -20 dB in 2 dB steps plus Silence (audio black)	User selectable, channel-by-channel
Rise and Fall Times	Between 5 and 30 nsec	Measure from the 10% to 90% points across 110 Ω .
Pre-emphasis		None
Jitter on Data transitions	Within ± 20 nsec from an ideal clock.	
Channel Status Bits		Uses default settings, except explicit data resolution status. Emphasis bits may be set to test receivers (but do not enable emphasis in the data). (See Table A-13.)

Table A-9: Signal Characteristics for AES/EBU Serial Digital Audio Outputs (BNC outputs)

Characteristics	Performance Requirements	Reference Information
Standards Conformance		SMPTE RP 155-1990
Audio Connectors	2	BNC connectors
Audio Timing		
Digital Format		Serial, (unbalanced) signal and a signal ground
Digital Code		Bi-phase mark
Output Level	$1\text{ V} \pm 0.2\text{ V}$	Measured across 75Ω .
Required Receiver Termination	$75\Omega \pm 10\%$	
Encoding Format		Linear PCM, two's complement binary representation.
Audio Sampling Frequency		48.000 kHz, locked to video
Number of Audio Channels	4	2 AES/EBU audio pairs on each audio connector
Quantized Resolution		20 or 24 bits (user selectable)
Audio Tone Frequency	800 Hz or 1 kHz or Silence (audio black)	User selectable, channel-by-channel
Audio Tone Amplitude	-10 to -20 dBFS, in 2 dB steps plus Silence (audio black)	User selectable, channel-by-channel
Jitter on Data Transitions	Within ± 20 nsec from an ideal clock	
Pre-emphasis		None
Rise and Fall Times	Between 30 and 44 nsec	Measured from the 10% to 90% points across 75Ω .
Channel Status Bits		Uses default settings, except explicit data resolution status. Emphasis bits may be set to test receivers (but do not enable emphasis in the data). (See Table A-13.)

Table A-10: Signal Characteristics for Embedded Serial Audio

Characteristics	Performance Requirements	Reference Information
Standards Conformance		SMPTE 259M, SMPTE 272M, and SMPTE 125M
Encoding Format		Linear PCM, two's complement binary representation
Audio Sampling Frequency		48.000 kHz, locked to video
Number of Audio Channels	4	
Quantized Resolution		20 bits
Audio Tone Frequency	800 Hz or 1 kHz or Silence (audio black)	User selectable, channel-by-channel
Audio Tone Amplitude	-10 to -20 dBFS, in 2 dB steps plus Silence (audio black)	User selectable, channel-by-channel
Pre-emphasis		None implemented in data.
Channel Status Bits		Uses default settings, except explicit data resolution status. Emphasis bits may be set to test receivers (but does not enable emphasis in the data). (See Table A-13.)
20-bit Audio Sample Distribution		See Table A-11. See Table A-12.

Table A-11: 20-bit Audio Signal Sample Distribution for Embedded Serial Audio on 525/59.94 Signals

Analog Field 1 Line Numbers	Transmitted Samples	Analog Field 2 Line Numbers	Transmitted Samples
5	4	268 (5)	4
10	0	273 (10)	0
11	0	274 (11)	0
12	0	275 (12)	0
13 ¹	3 / 4		
17	4	280 (17)	4
29	4	292 (29)	4
41	4	304 (41)	4
53	4	316 (53)	4
65	4	328 (65)	4
77	4	340 (77)	4
89	4	352 (89)	4
101	4	364 (101)	4
113	4	376 (113)	4
125	4	388 (125)	4
137	4	400 (137)	4
149	4	412 (149)	4
161	4	424 (161)	4
173	4	436 (173)	4
185	4	448 (185)	4
197	4	460 (197)	4
209	4	472 (209)	4
221	4	484 (221)	4
233	4	496 (233)	4
245	4	508 (245)	4
257	4	520 (257)	4
All Other Lines	3	All Other Lines	3

¹ Line 13 has 4 samples in Fields 1, 5, and 9.

Table A-12: 20-bit Audio Signal Sample Distribution for Embedded Serial Audio on 625/50 Signals

Analog Field 1 Line Numbers	Transmitted Samples	Analog Field 2 Line Numbers	Transmitted Samples
5	4	318 (5)	4
6	0	319 (6)	0
7	0	320 (7)	0
8	0	321 (8)	0
15	4	328 (15)	4
25	4	338 (25)	4
35	4	348 (35)	4
45	4	358 (45)	4
55	4	368 (55)	4
65	4	378 (65)	4
75	4	388 (75)	4
85	4	398 (85)	4
95	4	408 (95)	4
105	4	418 (105)	4
115	4	428 (115)	4
125	4	438 (125)	4
135	4	448 (135)	4
145	4	458 (145)	4
155	4	468 (155)	4
165	4	478 (165)	4
175	4	488 (175)	4
185	4	498 (185)	4
195	4	508 (195)	4
205	4	518 (205)	4
215	4	528 (215)	4
225	4	538 (225)	4
235	4	548 (235)	4
245	4	558 (245)	4
255	4	568 (255)	4
265	4	578 (265)	4
275	4	588 (275)	4
285	4	598 (285)	4
295	4	608 (295)	4
305	4	618 (305)	4
314	4		
All Other Lines	3	All Other Lines	3

Table A-13: Audio Channel Status Bits (Serial and Embedded Audio Data Streams)

Byte	Bit	Value	Function
0	0	1	Professional use of channel status
	1	0	Normal audio mode
	2-4	100 (default)	No emphasis
		110 (selectable)	50/15 sec emphasis
		111 (selectable)	CCITT J17 emphasis
5	0	Source sampling frequency locked	
6-7	01	48 kHz sampling frequency	
1	0-3	0001	Two-channel mode
	4-7	0001	192-bit block structure, preamble Z indicates start of block
2	0-2	000 (selectable)	Maximum 20-bit audio sample data
		001 (selectable)	Maximum 24-bit audio sample data (not available for embedded)
	3-5	101	Word length specified in bits 0-2
	6-7	00	Reserved
3	0-7	0000 0000	Reserved
4	0-7	0000 0000	Reserved
5	0-7	0000 0000	Reserved
6	0-7	0000 0001	Alphanumeric Channel - Origin
7	0-7	0000 0001	Alphanumeric Channel - Origin
8	0-7	0000 0001	Alphanumeric Channel - Origin
9	0-7	0000 0001	Alphanumeric Channel - Origin
10	0-7	0000 0001	Alphanumeric Channel - Destination
11	0-7	0000 0001	Alphanumeric Channel - Destination
12	0-7	0000 0001	Alphanumeric Channel - Destination
13	0-7	0000 0001	Alphanumeric Channel - Destination
14	0-7	0000 0000	Local Sample Address Code
15	0-7	0000 0000	Local Sample Address Code
16	0-7	0000 0000	Local Sample Address Code
17	0-7	0000 0000	Local Sample Address Code
18	0-7	0000 0000	Time Sample Address Code
19	0-7	0000 0000	Time Sample Address Code
20	0-7	0000 0000	Time Sample Address Code
21	0-7	0000 0000	Time Sample Address Code
22	0-3	0000	Reserved
	4-7	0000	Bytes 0-21 are reliable
23	0-7	(Depends on user choices shown above)	Channel status cyclic redundancy check character (over bytes 0-22) 0FX0, 0X55

Table A-14: Genlock Function

Characteristics	Performance Requirements	Reference Information
Input Configuration	One 75 Ω loopthrough or two 75 Ω terminating inputs	User selectable
Genlock Input Return Loss	≥ 40 dB	0 – 5 MHz
Isolation between two 75 Ω terminating inputs	≥ 60 dB	0 – 5 MHz
Internal Reference Free-Run Frequency	13.5 MHz \pm 13 Hz	1 ppm/year max drift combined with 1 year calibration cycle.
Pull-in Range	Subcarrier frequency \pm 20 Hz	
Genlock Input Signals		Burst locks to NTSC and PAL composite signals. Sync locks to monochrome NTSC and PAL signals. Carrier locks to 1, 3.58, 4.43, 5, and 10 MHz.
Carrier Lock Amplitude		2 V _{p-p} (8 dBm) nominal input level
Burst Lock Jitter	$\leq 0.5^\circ$	SNR ¹ >50 dB.
Genlock Noise Performance		Will remain locked with SNR > 30 dB or 60 Hz hum < 1 V _{p-p} .
Burst Lock Phase Change with Input Burst Amplitude	$\leq 1^\circ$	Over burst amplitude range of nominal value \pm 3 dB.
Burst Lock Phase Change with Input Signal APL	$\leq 1^\circ$	Over input signal APL range of 10% to 90%.
Sync Lock Jitter	≤ 0.6 nsec	($\approx 0.75^\circ$ at 3.58 MHz, $\approx 1^\circ$ at 4.43 MHz), SNR >50 dB
Sync Lock Timing Change with Input Sync Amplitude	≤ 2 nsec	Over sync amplitude range of nominal value +3 to -3 dB.
Input SC/H Phase Range for Correct Color Framing	$0^\circ \pm 45^\circ$	Will maintain initial color framing until the SC/H error exceeds 120 $^\circ$ nominally.
Genlock Timing Range	± 2 fields ± 8 lines $\pm 1/2$ line sub-clock-cycles	
Genlock Timing Resolution		< 0.1 $^\circ$ of subcarrier.

¹ SNR is defined as the ratio of 1 V_{p-p} video to the rms value of white gaussian noise over a 5 MHz bandwidth.

Table A-15: Power Supply

Characteristics	Performance Requirements	Reference Information
Supply Accuracy +12 V +5 V -5 V -12 V		+12 V \pm 300 mV +5 V \pm 100 mV -5.5 V \pm 500 mV -12 V \pm 300 mV
Current Limit +12 V +5 V -5 V -12 V		Total power limited to \approx 120 W.
Hum +12 V +5 V -5 V -12 V		Typical values: 10 mV 10 mV 20 mV 10 mV
Noise +12 V +5 V -5 V -12 V		(5 MHz measurement bandwidth) \leq 50 mV \leq 50 mV \leq 50 mV \leq 50 mV
Line Voltage Range	90 – 250 VAC	
Crest Factor		\geq 1.35
Fuse Required		2 A med. blow (110 V operation) 1 A med. blow (220 V operation)
Power Consumption		60 W maximum
Power Line Frequency		48 to 62 Hz

Table A-16: Mechanical (Physical) Characteristics

Characteristics	Reference Information
Rackmount Dimensions	
Height	1.734 inches (4.4 cm)
Width	19.0 inches (48.3 cm)
Length	22.1 inches (56.1 cm)
Net Weight	13.5 lbs. (6.14 kg)
Shipping Weight	22 lbs., 14 oz. (10.4 kg)

Table A-17: Environmental Characteristics

Characteristics	Reference Information
Temperature	
Non-operating	-40° C to +65° C
Operating	0° C to +50° C IEC 1010-1 compliance to +40° C.
Altitude	
Non-operating	To 50,000 feet
Operating	To 15,000 feet (4572) Meters) IEC 1010-1 compliance to 2000 Meters.
Humidity	5 – 95% humidity, non-condensing
Vibration	
Operating	From 5 to 350 Hz: 0.0002 g ² /Hz Acceleration Power Spectral Density (APSD) From 350 to 500 Hz: -3 dB/Octave Slope At 500 Hz: 0.00014 g ² /Hz APSD 0.31 GRMS Overall 10 Minutes/Axis
Non-operating	From 5 to 100 Hz: 0.020 g ² /Hz (APSD) From 100 to 200 Hz: -3 dB/Octave Slope From 200 to 350 Hz: 0.010 g ² /Hz APSD From 350 to 500 Hz: -3 dB/Octave Slope At 500 Hz: 0.007 g ² /Hz APSD 2.46 overall GRMS 10 minutes/axis
Shock	
Non-operating	Half Sine Wave Shock Levels: 50 g's (instrument), 11 msec duration, 3 shocks per direction.
Transportation	Qualified under NTSC Test Procedure 1A, Category II (24-inch drop)
Vehicle Vibration (Random Vibration)	Vibrate along all three axes at an overall vibration level of 1.33 GRMS. One hour per axis.

Table A-17: Environmental Characteristics (cont.)

Characteristics	Reference Information
Second Manual Handling (Shock)	Drop on all sides once from a height of 24 inches. Drop on the bottom from a height of 48 inches.
Equipment Type	Test
Equipment Class	Class I (grounded product) (as defined in IEC 1010-1, Annex H)
Installation Category	Installation Category II (as defined in IEC 1010-1, Annex J) Rated for indoor use only.
Pollution Degree	Pollution Degree 2 (as defined in IEC 1010-1)

Table A-18: Certifications and Compliances

EC Declaration of Conformity – EMC	Meets intent of Directive 89/336/EEC for Electromagnetic Compatibility. Compliance was demonstrated to the following specifications as listed in the Official Journal of the European Communities: EN 50081-1 Emissions: EN 55022 Class B Radiated and Conducted Emissions EN 60555-2 AC Power Line Harmonic Emissions EN 50082-1 Immunity: IEC 801-2 Electrostatic Discharge Immunity IEC 801-3 RF Electromagnetic Field Immunity IEC 801-4 Electrical Fast Transient/Burst Immunity IEC 801-5 Power Line Surge Immunity High-quality shielded cables must be used to ensure compliance with the above listed standards
FCC Compliance	Emissions comply with FCC Code of Federal Regulations 47, Part 15, Subpart B, Class A Limits
EC Declaration of Conformity – Low Voltage	Compliance was demonstrated to the following specification as listed in the Official Journal of the European Communities: Low Voltage Directive 73/23/EEC EN 61010-1:1993 Safety requirements for electrical equipment for measurement, control, and laboratory use
Approvals	UL3111-1 – Standard for electrical measuring and test equipment CAN/CSA C22.2 No. 1010.1 – Safety requirements for electrical equipment for measurement, control and laboratory use

Table A-18: Certifications and Compliances (cont.)

Installation Category Descriptions	Terminals on this product may have different installation category designations. The installation categories are:
CAT III	Distribution-level mains (usually permanently connected). Equipment at this level is typically in a fixed industrial location
CAT II	Local-level mains (wall sockets). Equipment at this level includes appliances, portable tools, and similar products. Equipment is usually cord-connected
CAT I	Secondary (signal level) or battery operated circuits of electronic equipment

Signal Illustrations

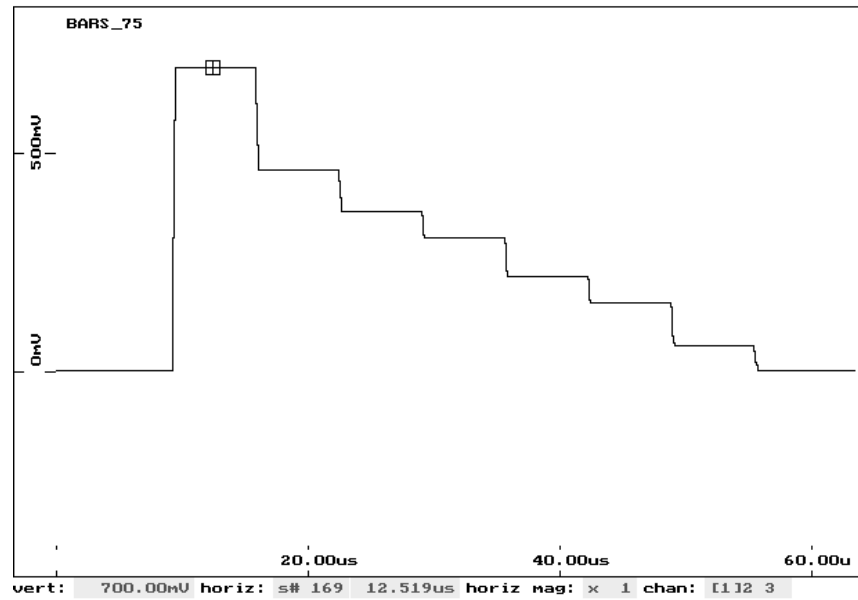

Figure A-8: 75% Color Bars — Y Channel

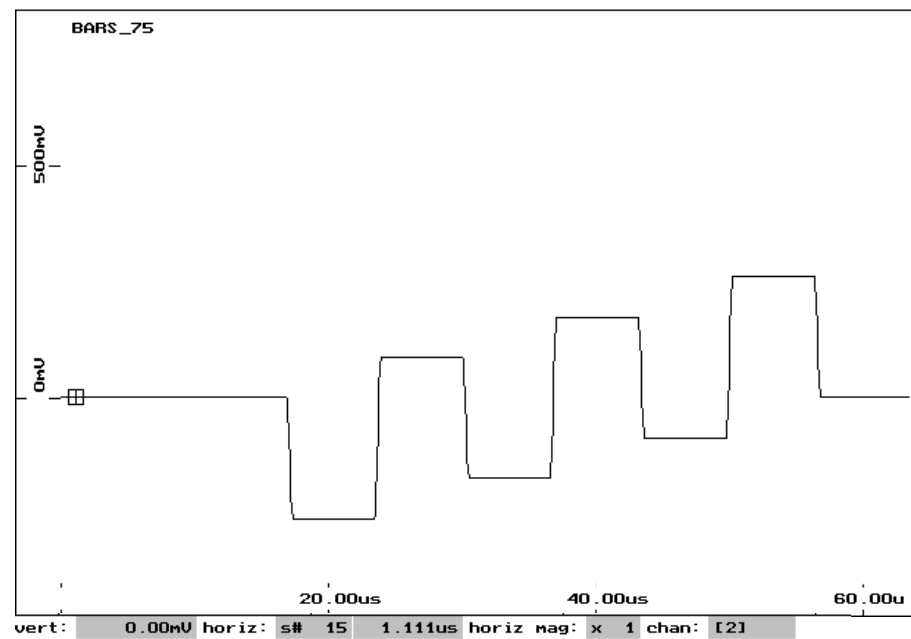

Figure A-9: 75% Color Bars — C_B Channel

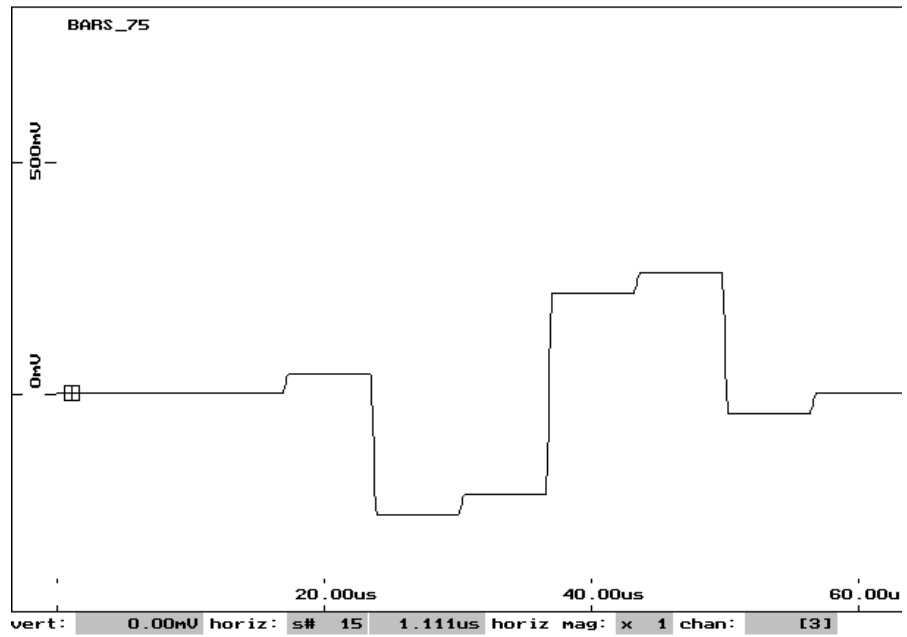

Figure A-10: 75% Color Bars — C_R Channel

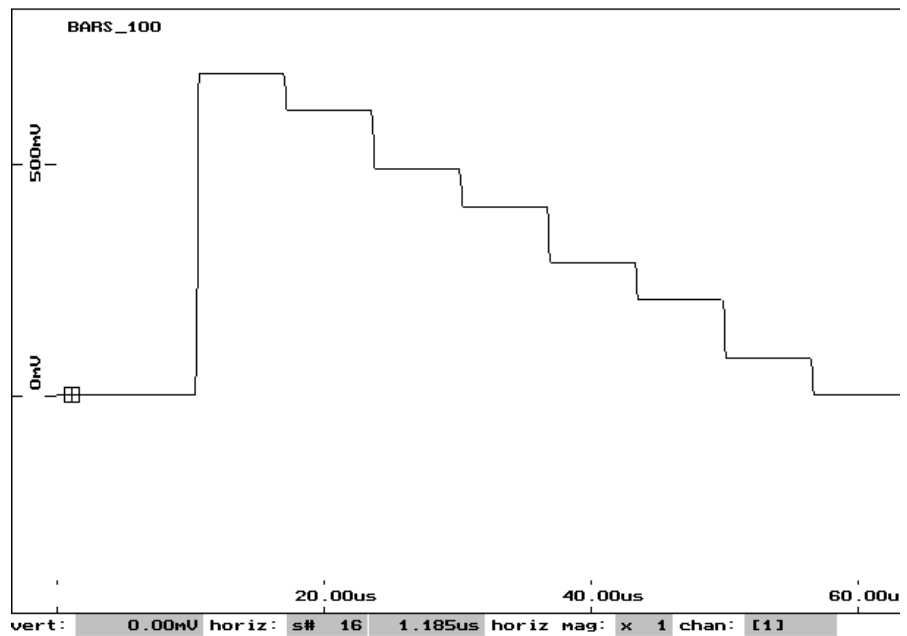

Figure A-11: 100% Color Bars — Y Channel

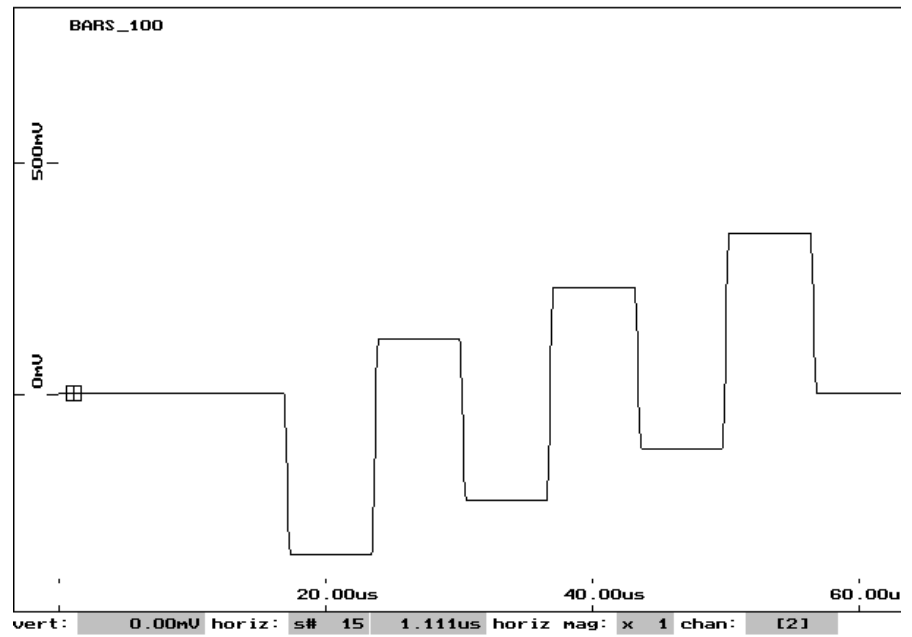

Figure A-12: 100% Color Bars — C_B Channel

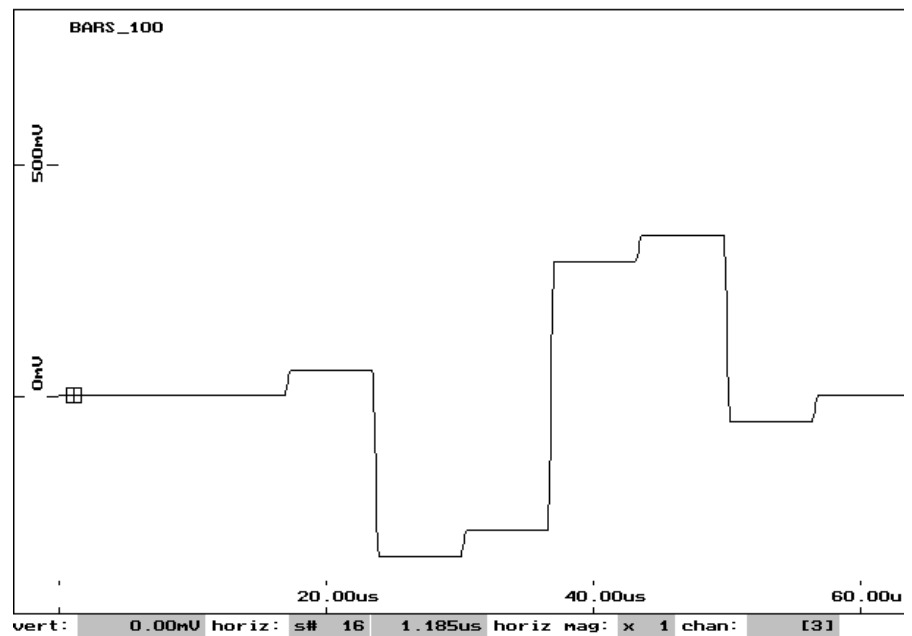

Figure A-13: 100% Color Bars — C_R Channel

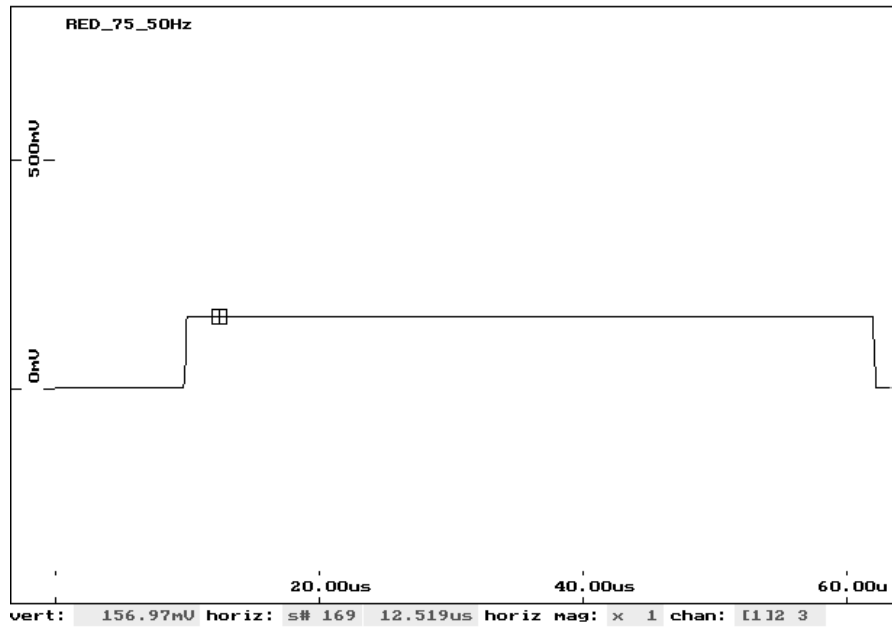

Figure A-14: 75% Red — Y Channel

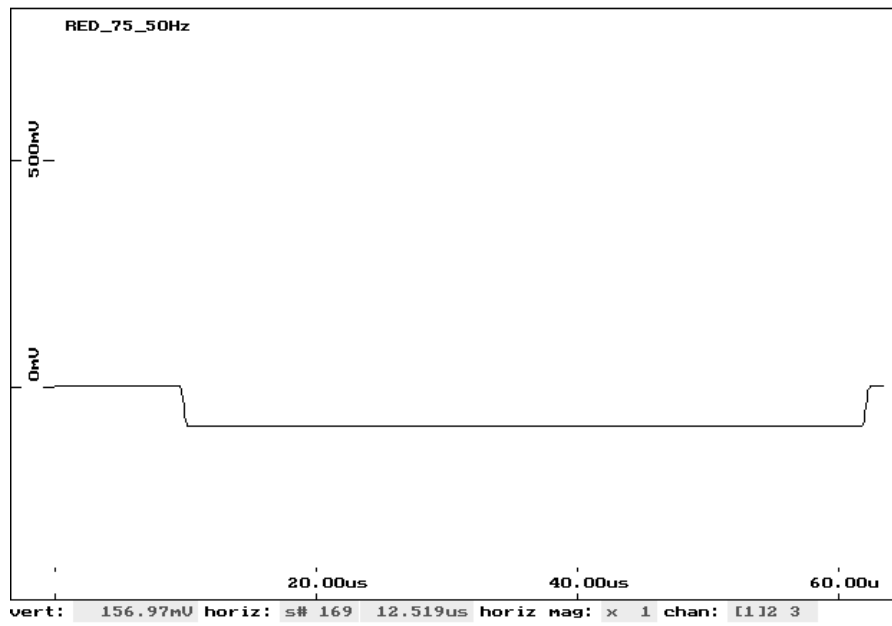

Figure A-15: 75% Red — C_B Channel

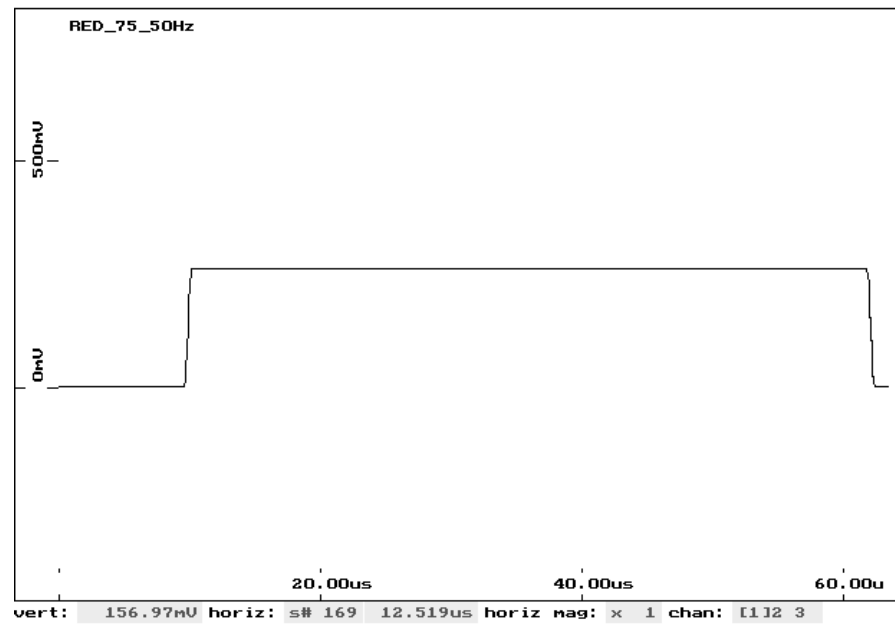

Figure A-16: 75% Red — C_R Channel

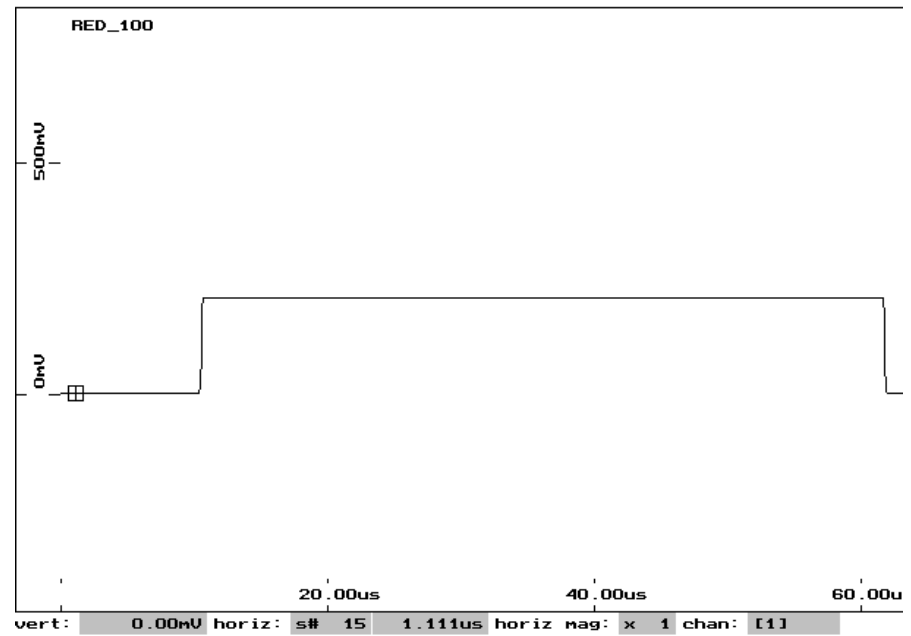

Figure A-17: 100% Red — Y Channel

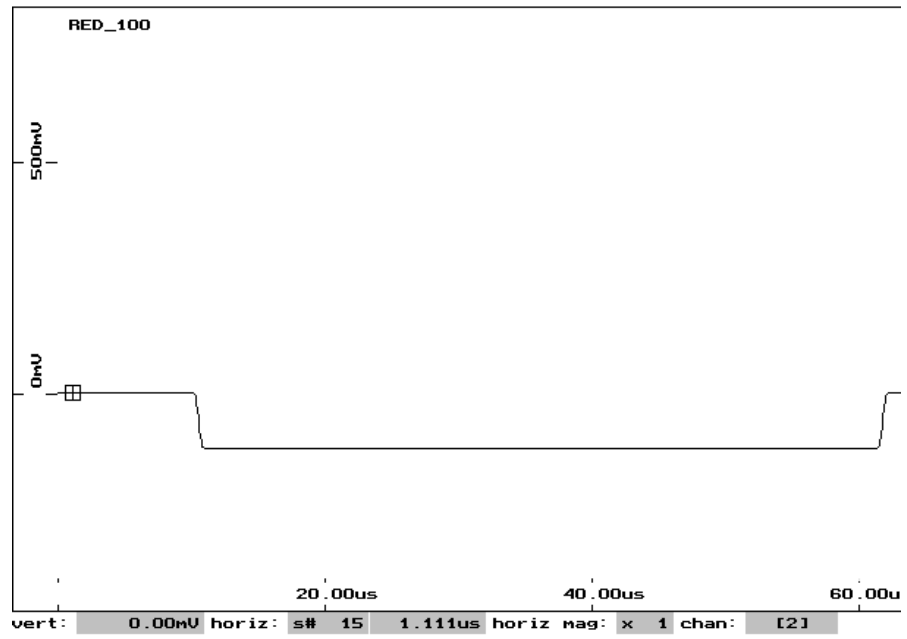

Figure A-18: 100% Red — C_B Channel

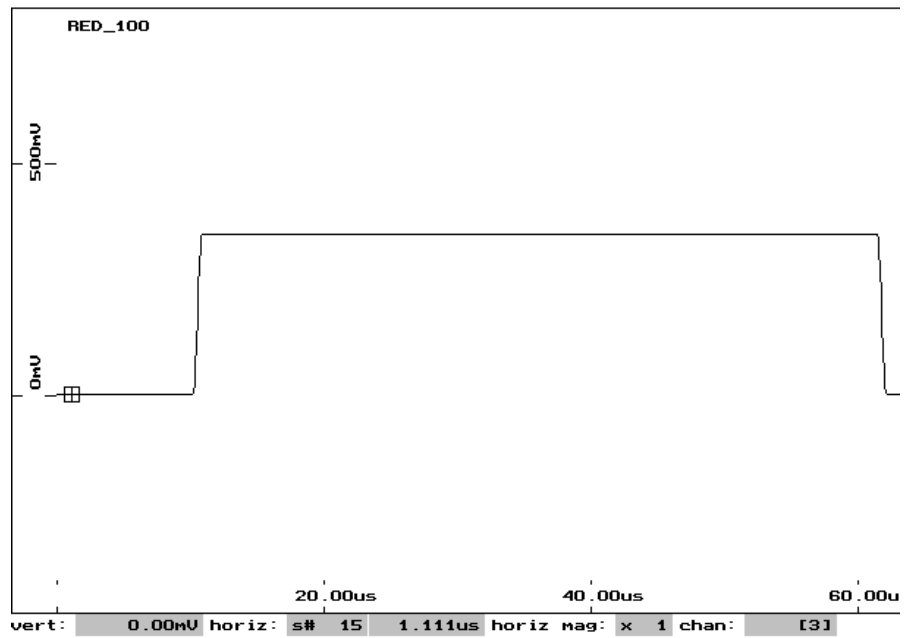

Figure A-19: 100% Red — C_R Channel

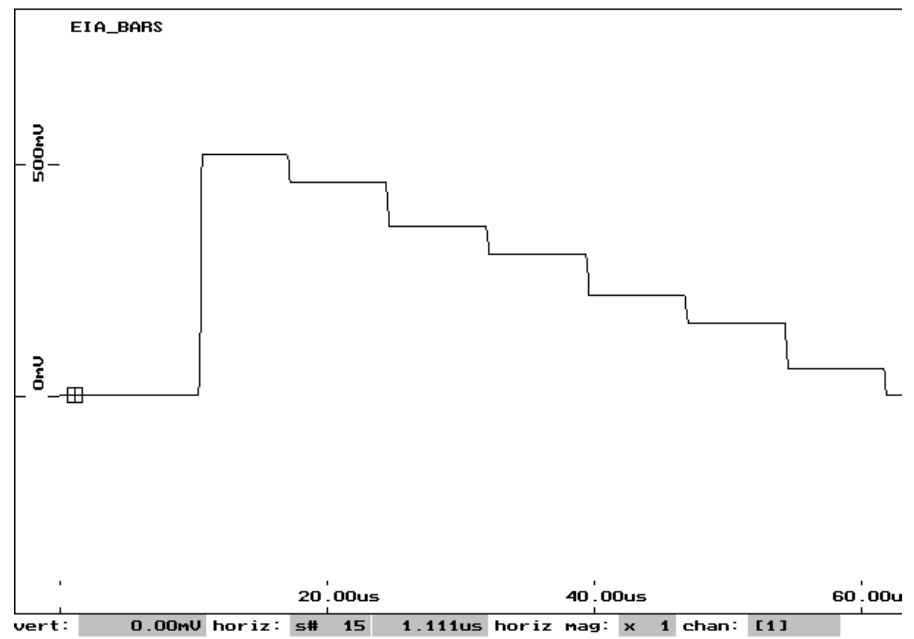

Figure A-20: EIA Bars (Part of SMPTE Bars) — Y Channel

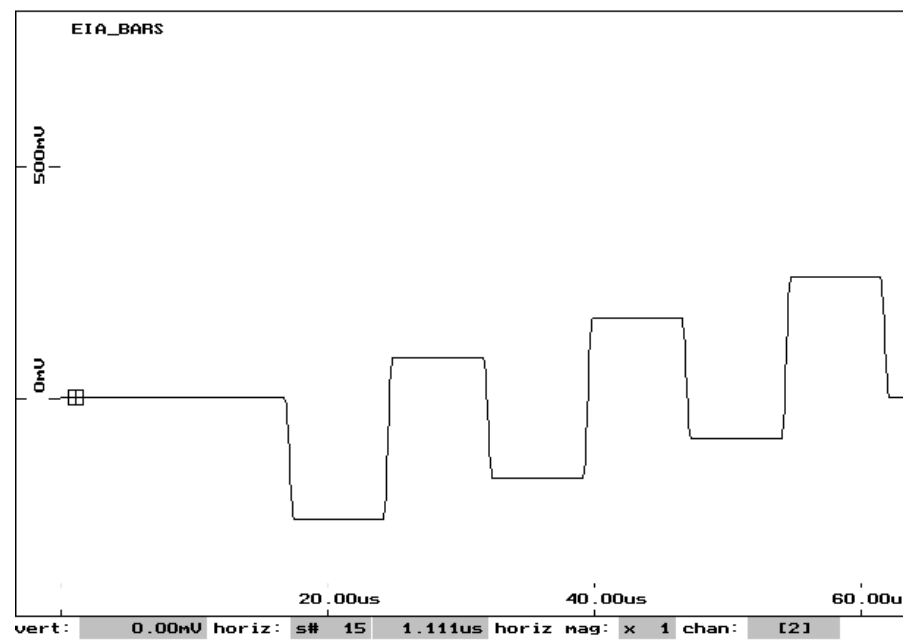

Figure A-21: EIA Bars (Part of SMPTE Bars) — C_B Channel

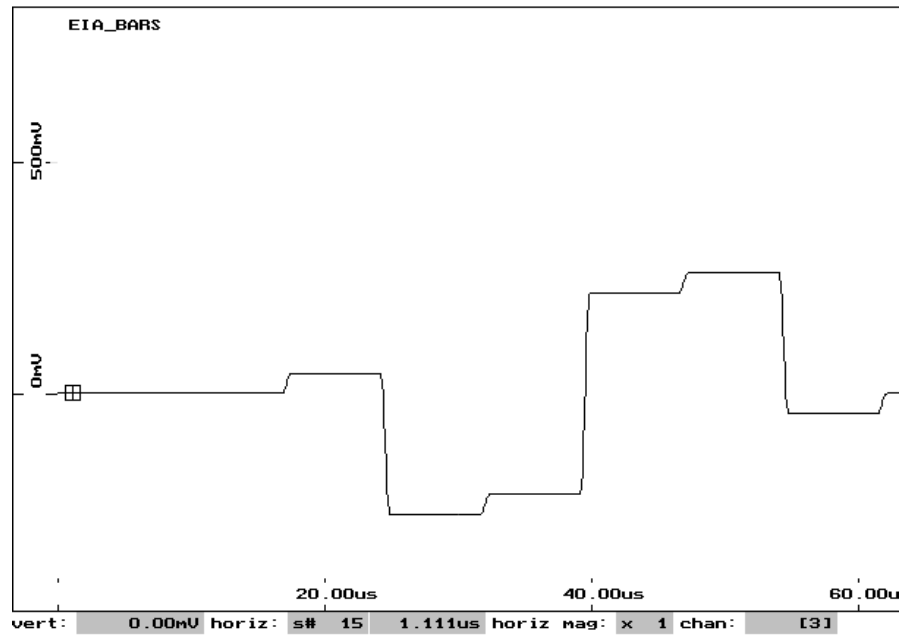

Figure A-22: EIA Bars (Part of SMPTE Bars) — C_R Channel

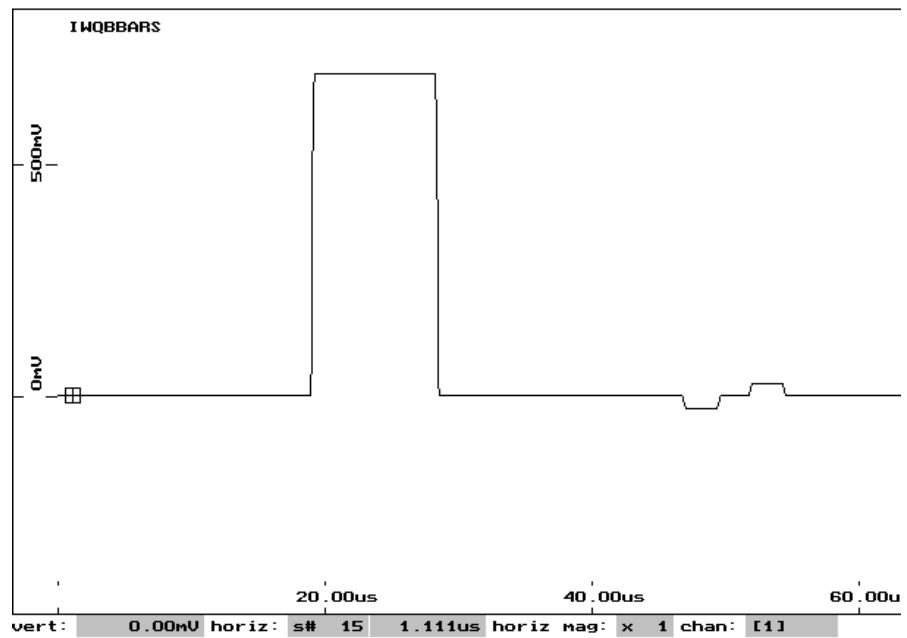

Figure A-23: IWQ Bars (Part of SMPTE Bars) — Y Channel

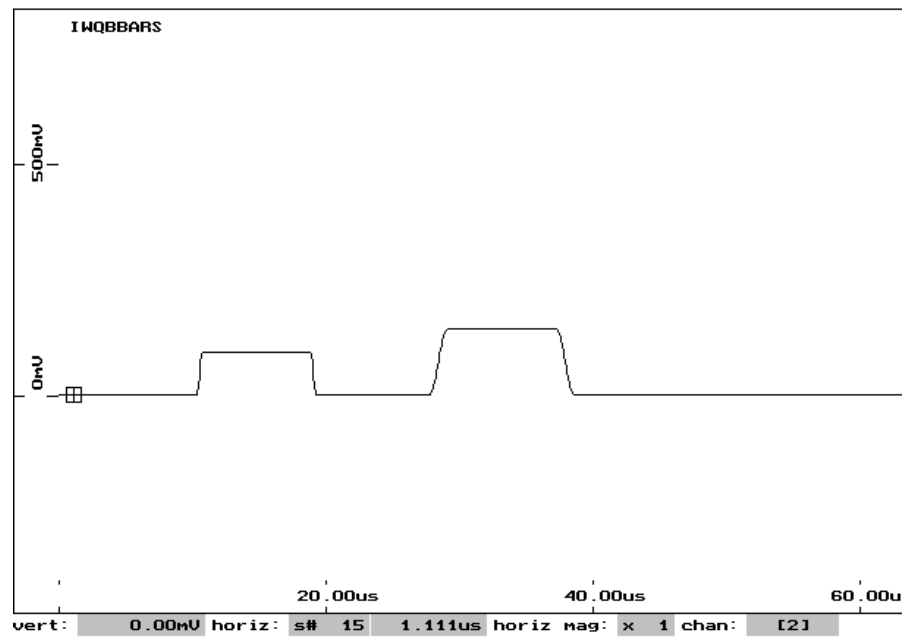

Figure A-24: IWQ Bars (Part of SMPTE Bars) — C_B Channel

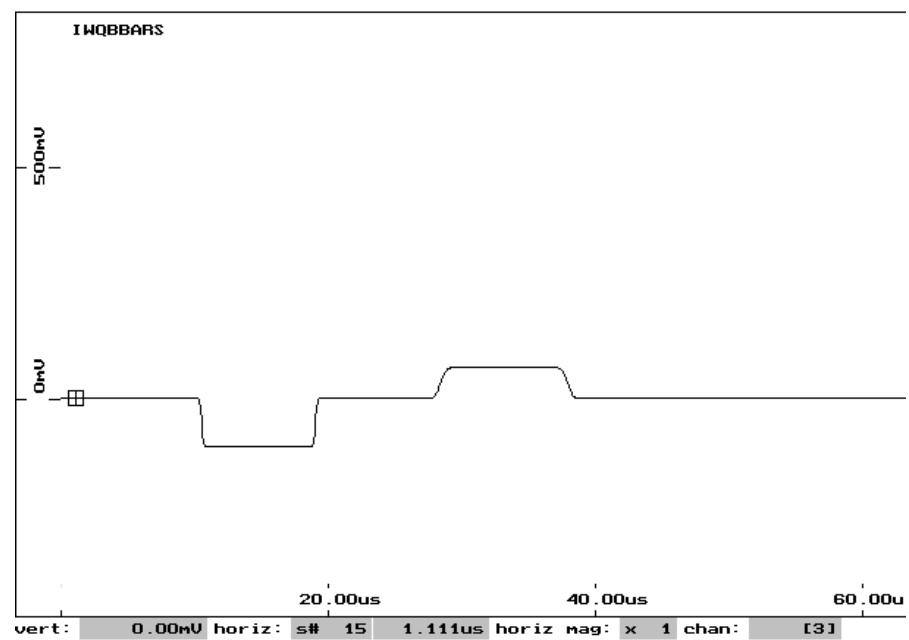

Figure A-25: IWQ Bars (Part of SMPTE Bars) — C_R Channel

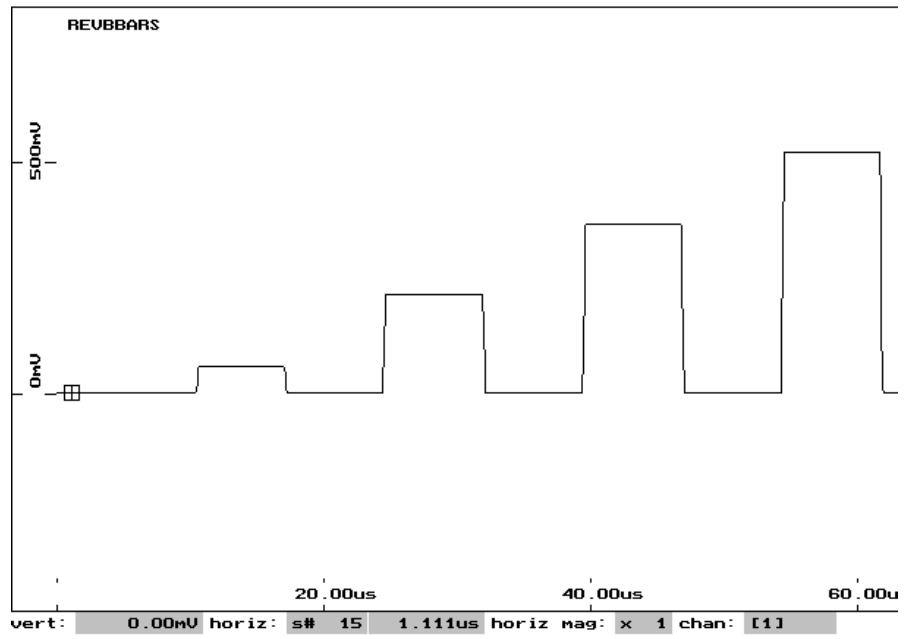

Figure A-26: Reverse Bars (Part of SMPTE Bars) — Y Channel

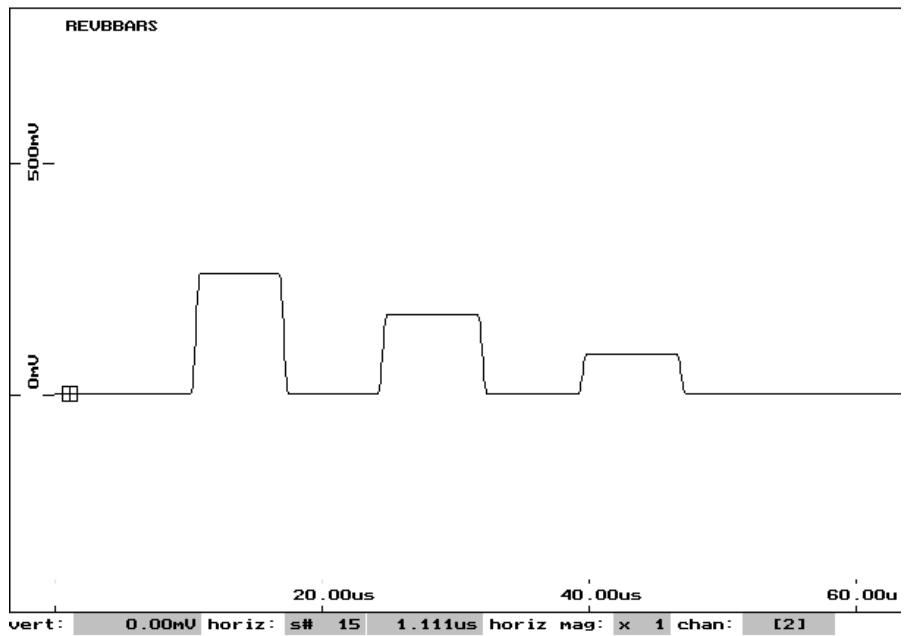

Figure A-27: Reverse Bars (Part of SMPTE Bars) — C_B Channel

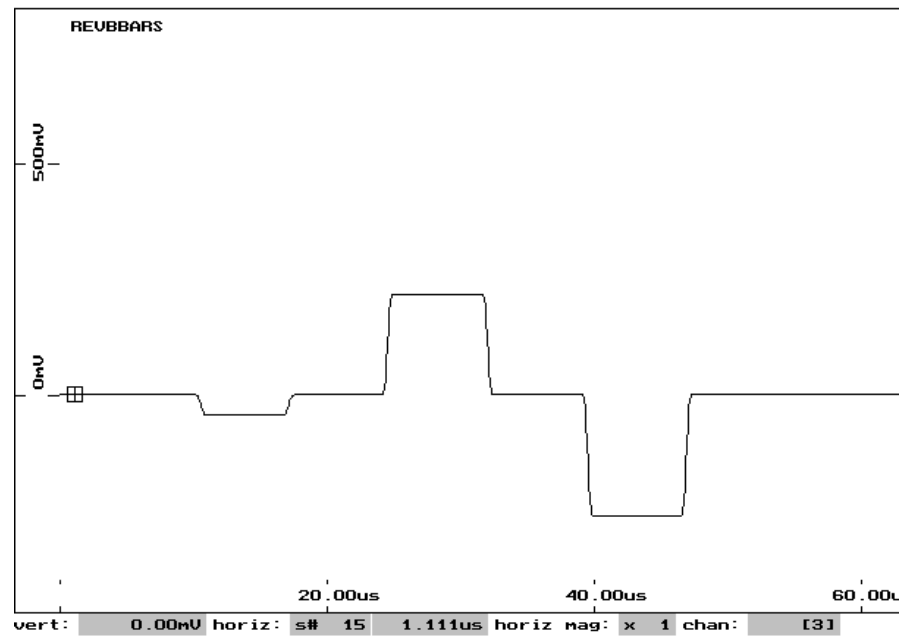

Figure A-28: Reverse Bars (Part of SMPTE Bars) — C_R Channel

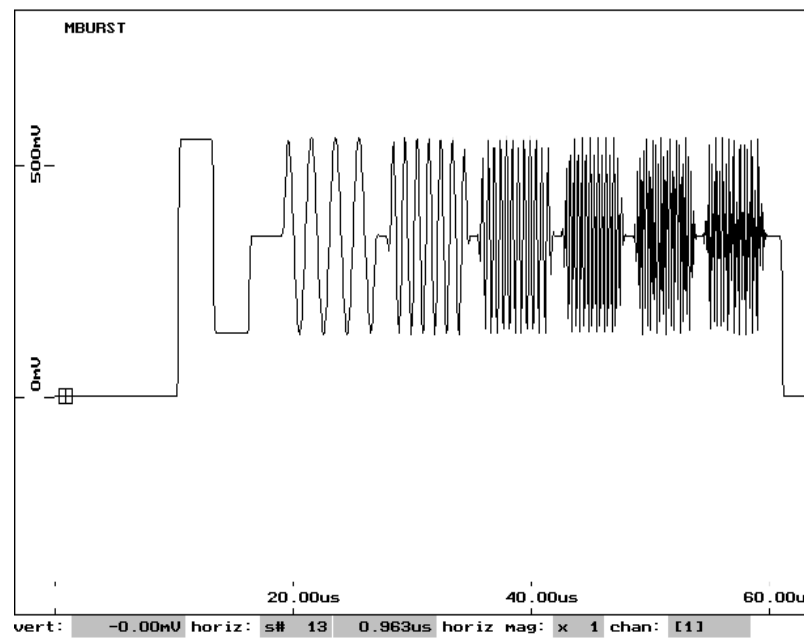

Figure A-29: Multiburst — Y Channel

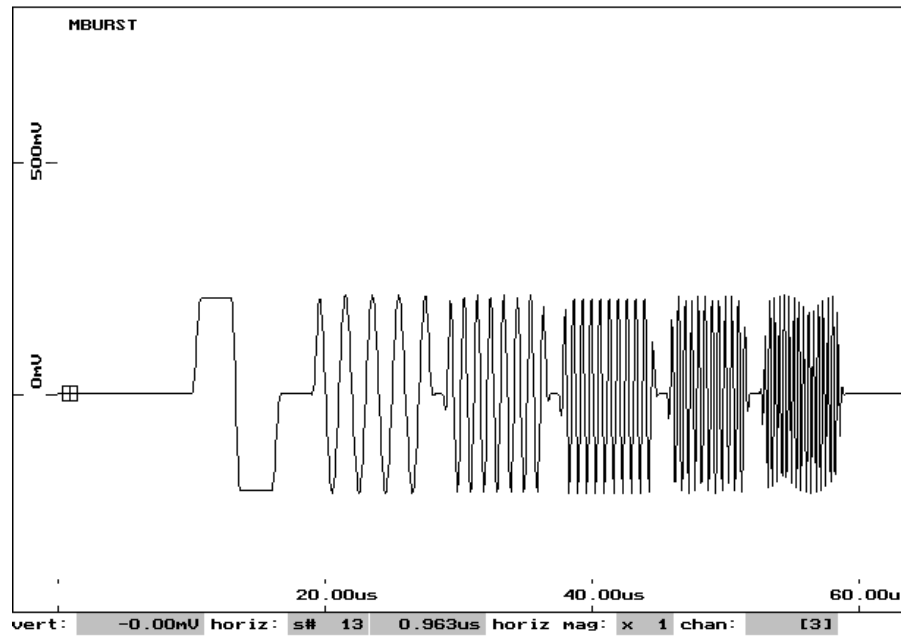

Figure A-30: Multiburst — C_B and C_R Channels

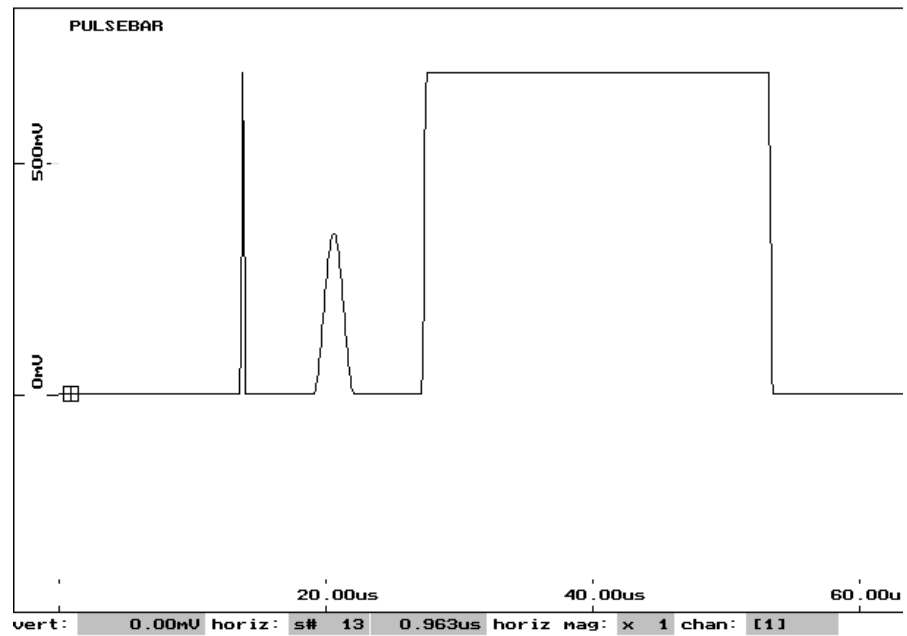

Figure A-31: Modulated Pulse and Bar — Y Channel

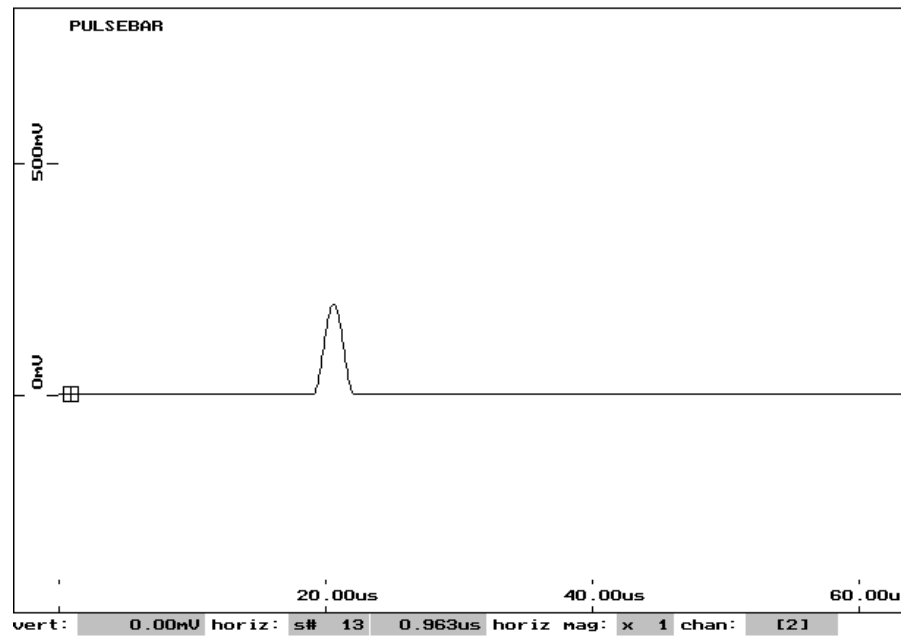

Figure A-32: Modulated Pulse and Bar — C_B Channel

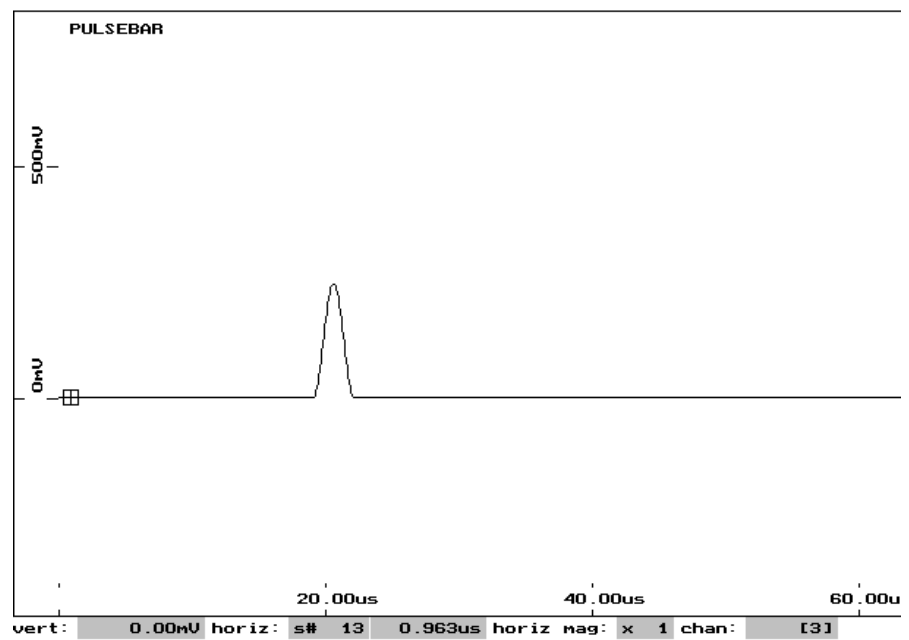

Figure A-33: Modulated Pulse and Bar — C_R Channel

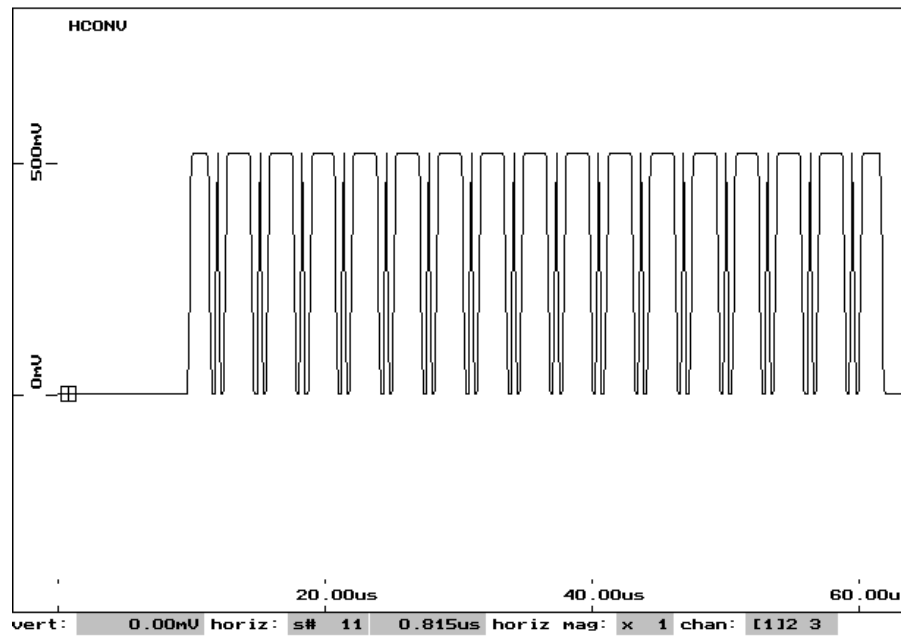

Figure A-34: Convergence (Horizontal) — Y Channel

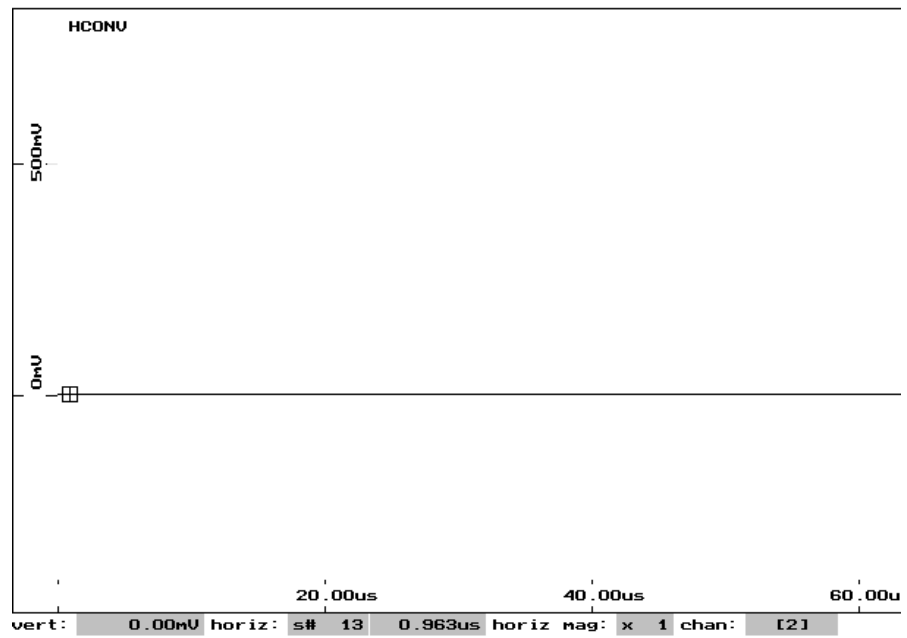

Figure A-35: Convergence (Horizontal) — C_B and C_R Channels

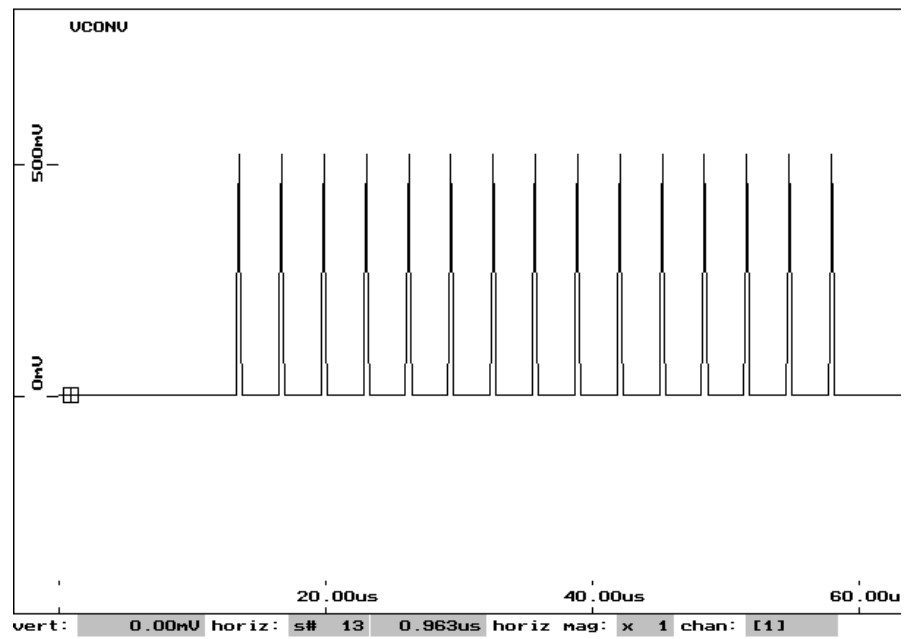

Figure A-36: Convergence (Vertical) — Y Channel

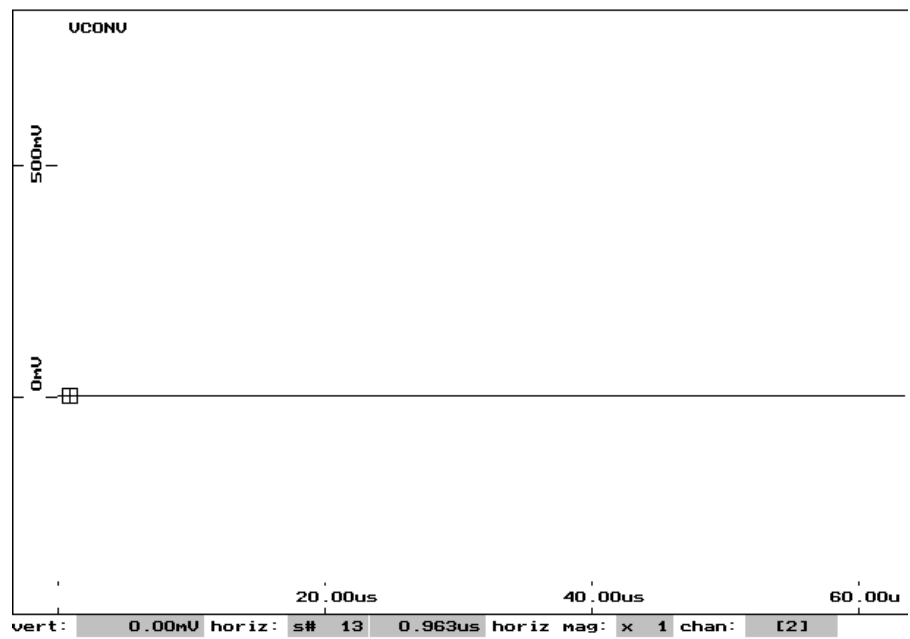

Figure A-37: Convergence (Vertical) — C_B and C_R Channels

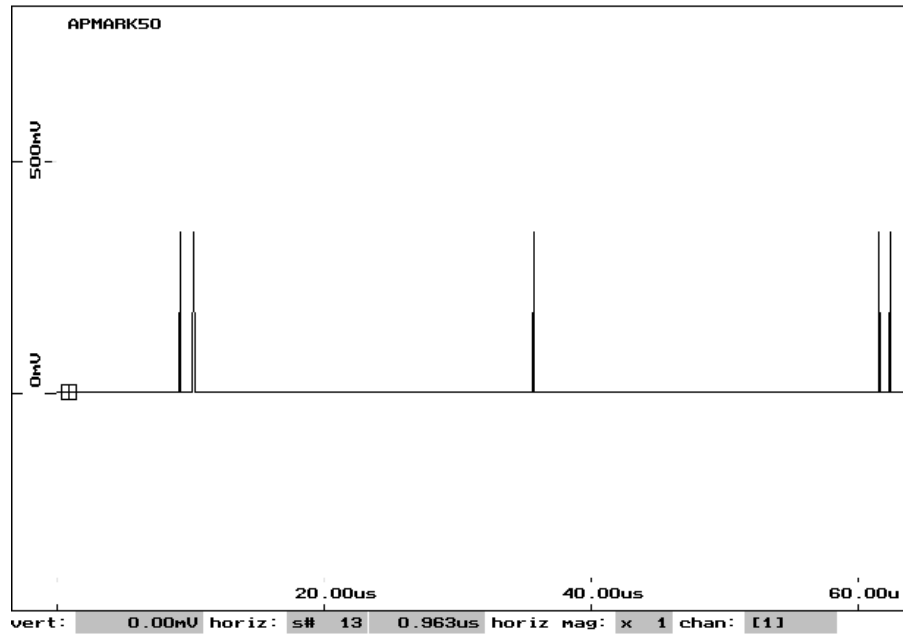

Figure A-38: Active Picture Markers (Part of Active Picture Timing Test Signal) — Y Channel

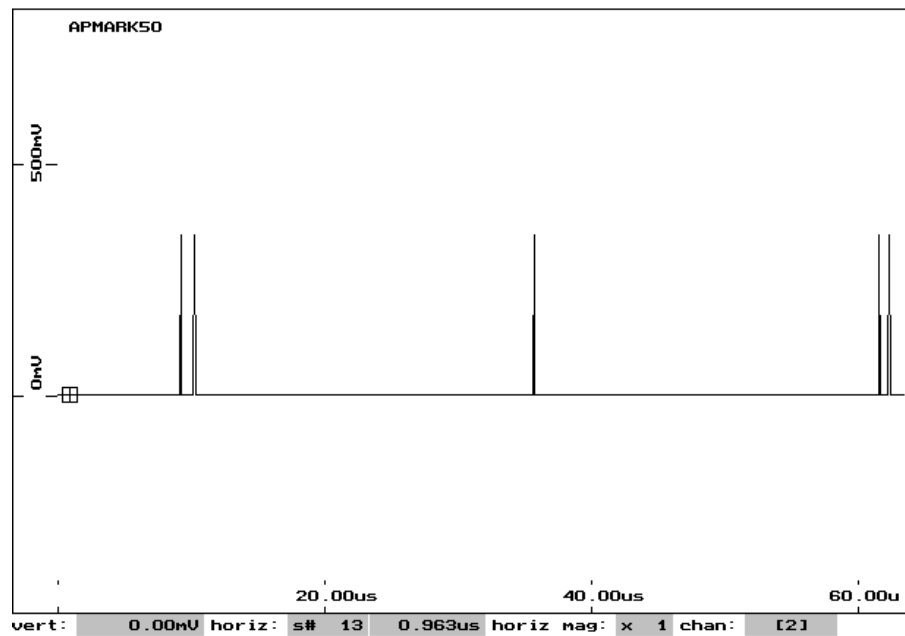

Figure A-39: Active Picture Markers (Part of Active Picture Timing Test Signal) — C_B

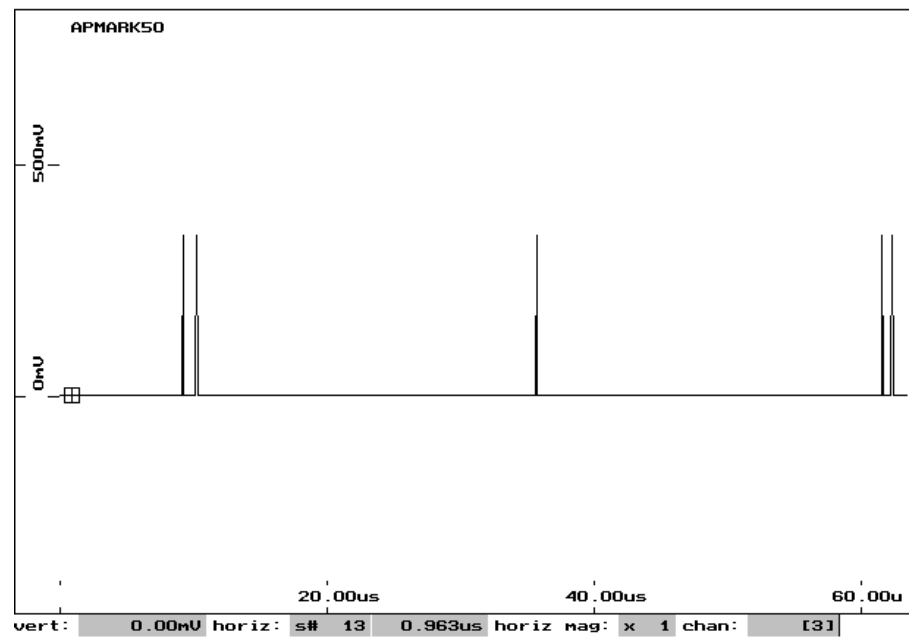

Figure A-40: Active Picture Markers (Part of Active Picture Timing Test Signal) — C_R

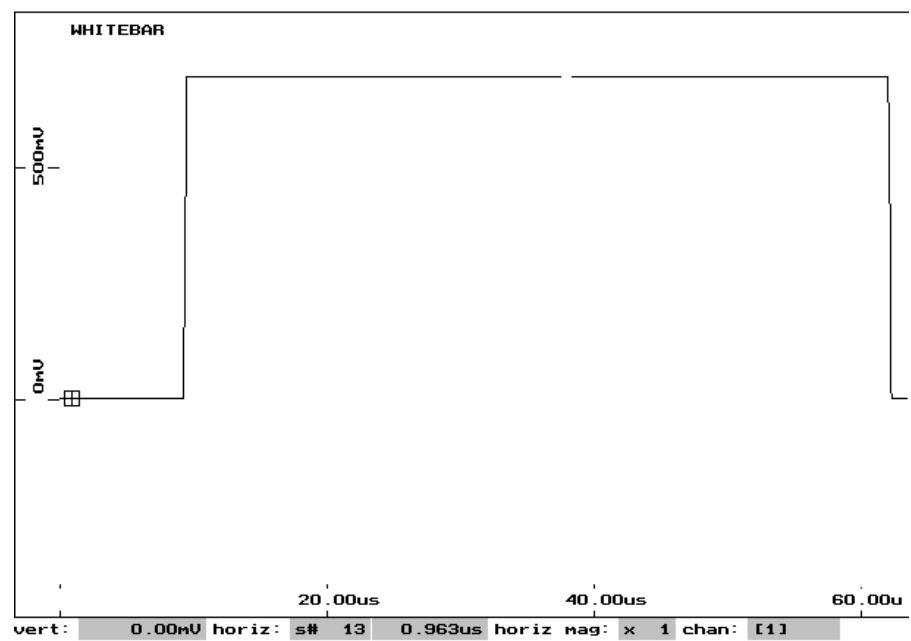

Figure A-41: White Bar (Also Part of Active Picture Timing Test Signal) — Y Channel

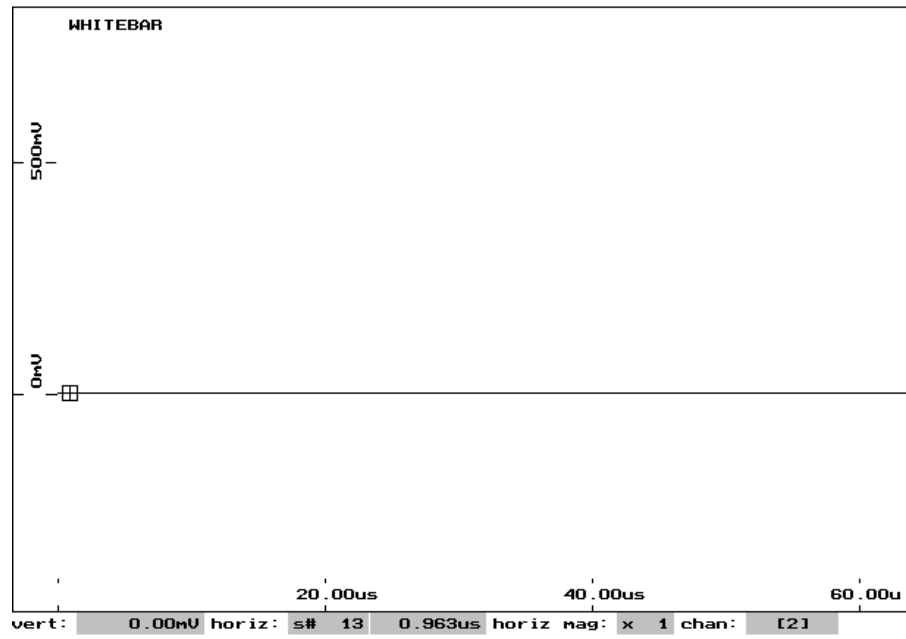

Figure A-42: White Bar (Also Part of Active Picture Timing Test Signal) — C_B and C_R Channels

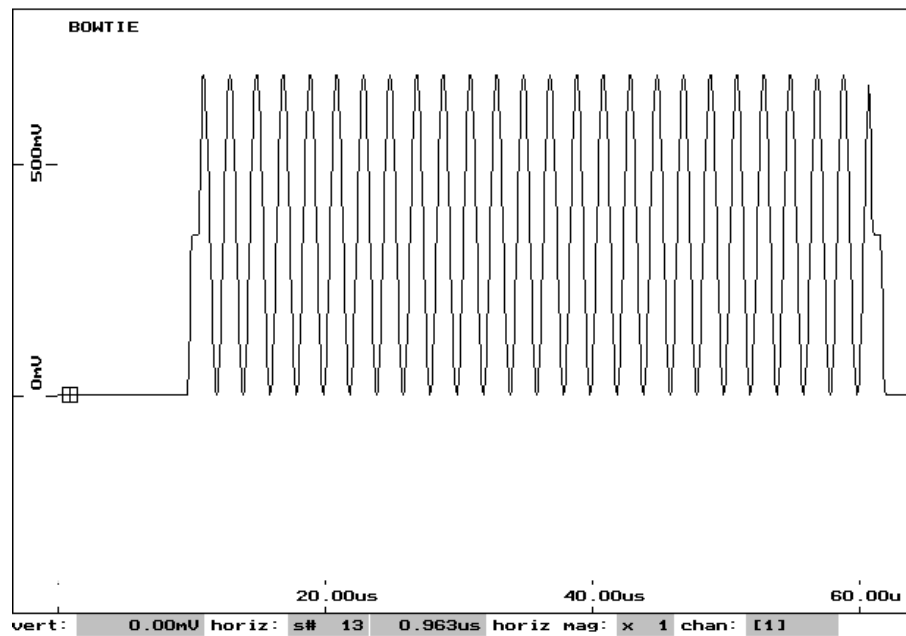

Figure A-43: Bowtie Sweep — Y Channel

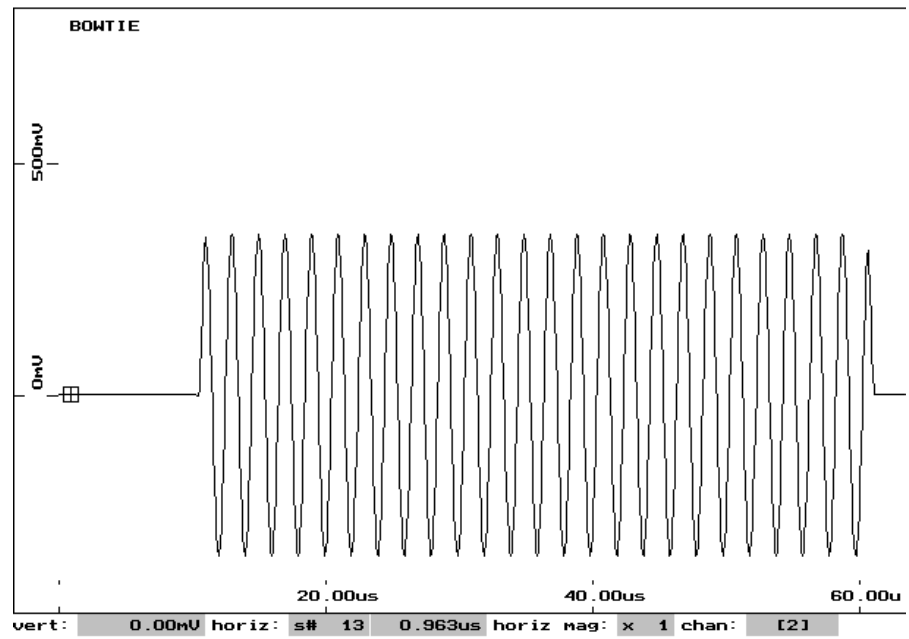

Figure A-44: Bowtie — C_B and C_R Channels

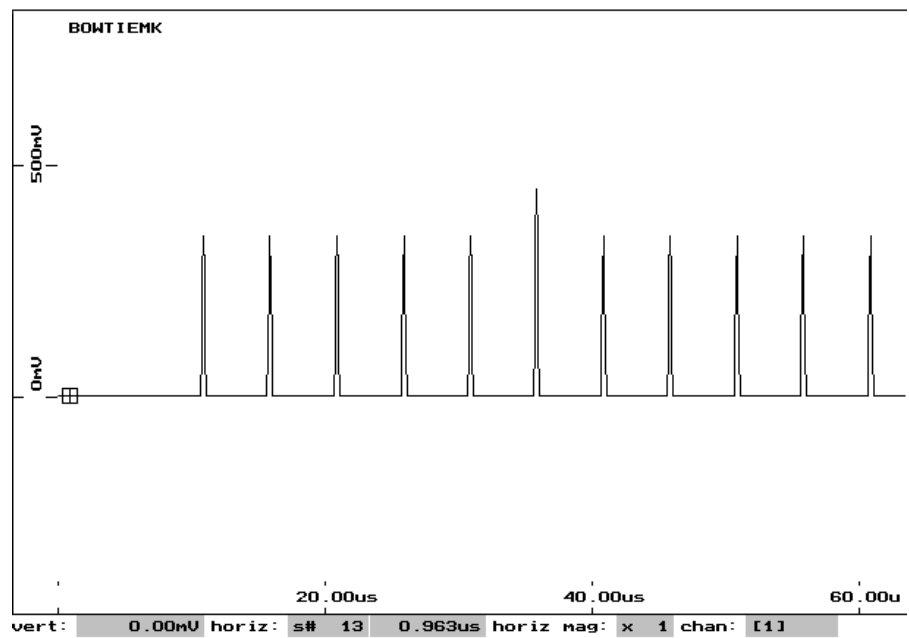

Figure A-45: Bowtie Markers — Y Channel

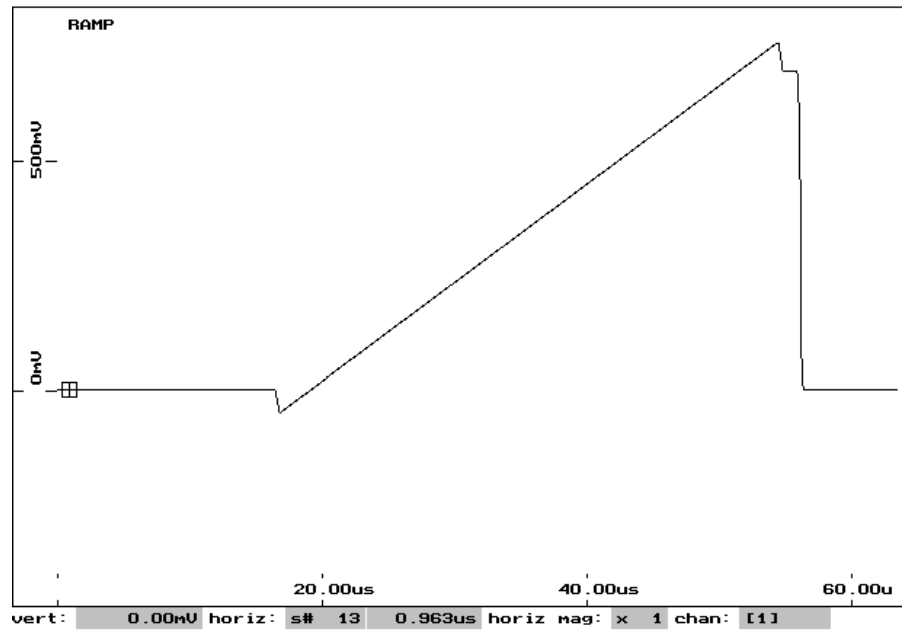

Figure A-46: Ramp — Y Channel

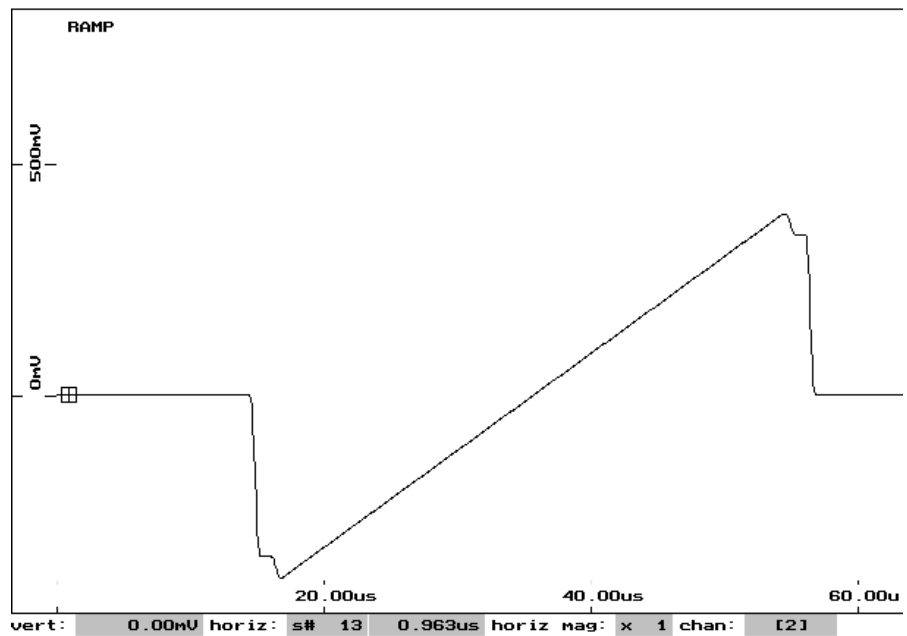

Figure A-47: Ramp — C_B Channel

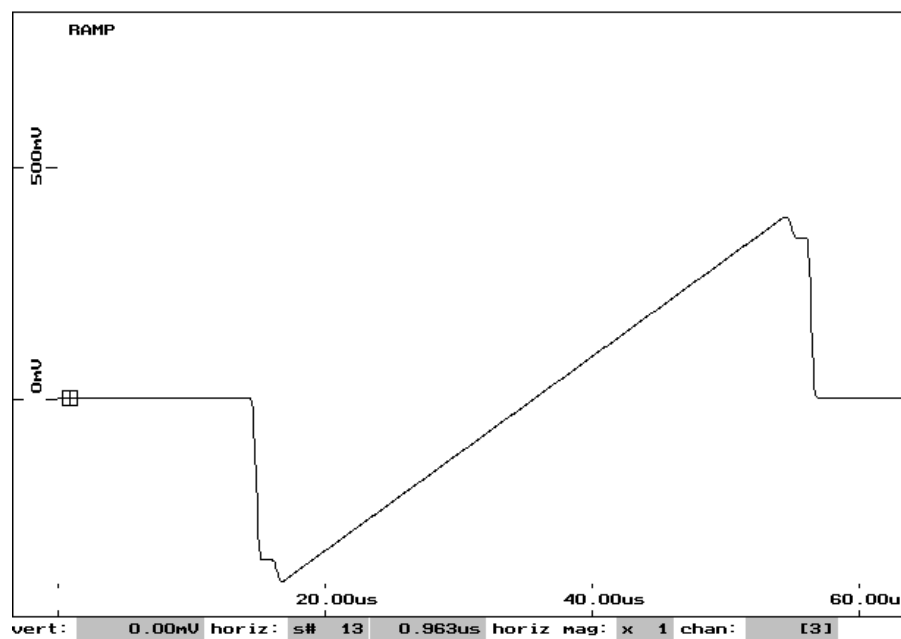

Figure A-48: Ramp — C_R Channel

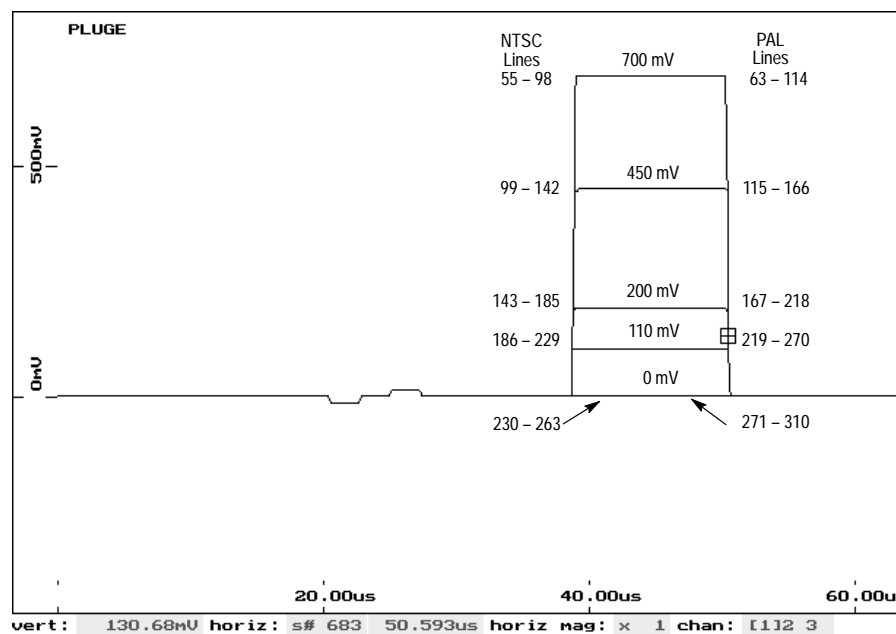

Figure A-49: Pluge — Y Channel

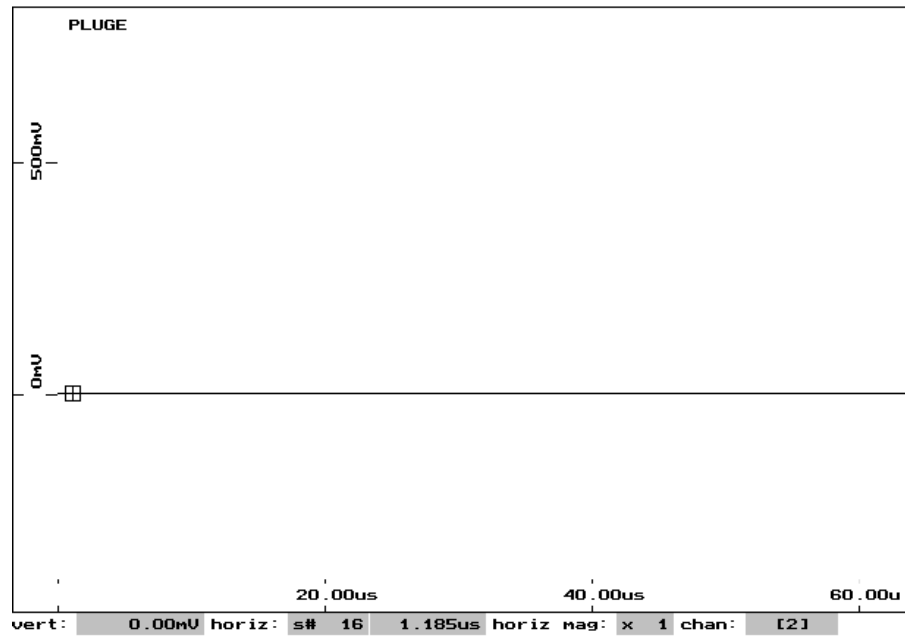

Figure A-50: Pluge — C_B and C_R Channels

